



## Packaging Guidelines for Shipping Freight

At FedEx, we know proper packaging of your freight is the best way to ensure that your goods arrive safely at their destination. So we offer these guidelines for shipments weighing more than 150 lbs.



# FedEx Guidelines for Shipments Weighing More Than 150 Lbs.

Start with an understanding of the FedEx Express and FedEx Freight shipping conditions and proceed to the specific guidelines and requirements for palletizing and preparing your freight shipments.

## Contents

Shipping and Handling Considerations	3
Stacking, Pallets and Crating	4
Cushioning, Blocking and Bracing	9
Banding and Stretchwrapping	10
Securing Unique Freight	11
Marking and Labeling	15
Contacts and Resources	17



## Shipping and Handling Considerations

When it comes to shipping freight, size, weight, climate and general handling issues come into play because often it takes multiple vehicles to deliver your goods to their final destination. FedEx Express Freight and FedEx Freight share freight-packaging guidelines and requirements with some exceptions. For specific terms and conditions governing FedEx Express® Freight and FedEx Freight® shipments, go to [fedex.com/us/services](https://www.fedex.com/us/services).

### FedEx Express Freight



### FedEx Freight



## Size, Weight and Climate:

### FedEx Express Freight

FedEx Express Freight shipments must be on a pallet, skid, or other forkliftable and pallet-jackable base with a minimum clearance of 3-1/2" for access, and should be stackable. Pallet-jack entry is required on two sides of the base. You may ship individual skids of 151 lbs. or more. Skids exceeding 2,200 lbs. require prior approval. Total shipment weight is unlimited. Skids measuring in excess of 70" high or 119" long or 80" wide require prior approval.

Individual pieces over 150 lbs. should be banded to the pallet with either metal strapping or unbreakable plastic straps applied around the box or skid freight on all sides.

Hardened containers (plywood, metal) that are not banded should have an exterior lock or clamp. (Glue, nails and screws are not sufficient.)

Take a look at our FedEx Express freight air cargo compartments and standard distribution and delivery truck dimensions, and you'll see why we have specific size recommendations for freight shipments.

On board FedEx Express® aircraft, temperatures vary depending on the type of aircraft, the location of each cargo compartment and the package location within each compartment, the length of flight, and the cruising altitude. For general reference, temperatures aboard most wide-body aircraft main cargo compartments vary between 65 F (18 C) and 90 F (32 C). Packages positioned

in the bulk compartment, next to the aircraft's outer structure, might be exposed to temperatures as low as 0 F (-18 C) during flight.

Air pressures on FedEx Express aircraft vary from as low as 8.3 psi at cruise altitude to as much as 14.7 psi on the ground.

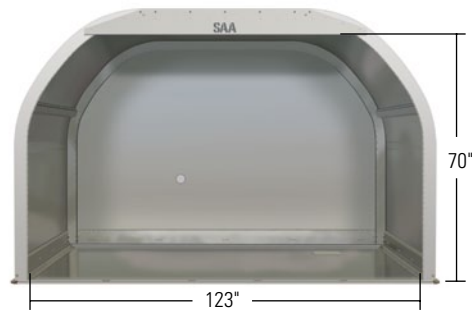

Our SAA cargo carrier measures 70"H x 123"W x 88"D.

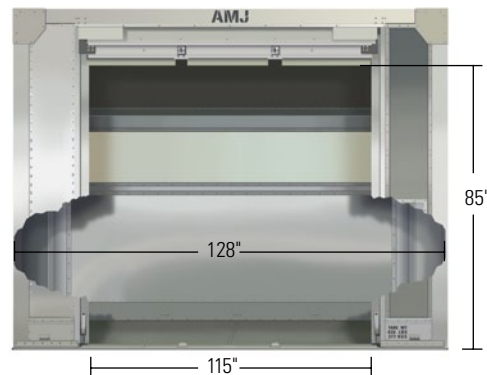

Based on door entry, our AMJ cargo carrier measures 85"H x 128"W x 88"D.



## FedEx Freight

FedEx Freight shipments may be palletized or nonpalletized, weigh up to 20,000 lbs. and measure up to 21 feet in length.

## FedEx Express Freight and FedEx Freight

The cargo areas of our trucks are not temperature-controlled, and temperature will vary depending on time of year, location, exposure to sunlight and other variables. In summer months, the temperature in the cargo area can be as much as 30 degrees higher than the ambient temperature outside the vehicle.

## Compression, Shock and Vibration: FedEx Express Freight and FedEx Freight

Your freight shipment will likely face forklifts, conveyor belts and multiple transport vehicles along its way to its final destination, so in addition to size, weight and climate recommendations, proper packaging also helps cushion goods to withstand ordinary care in handling.

## Stacking, Pallets and Crating

The orientation of cartons in your palletized freight shipments can have a big impact on the integrity of your shipments. FedEx Packaging Services suggests that you adhere to the following guidelines. You'll find examples of appropriate options for palletized freight shipping and some common — but not advisable — practices. Plus you'll get practical suggestions for manufacturing skids and crating materials.

## Recommended: Column Stack

Column-stack loads for palletized freight. In almost all cases it increases the top-to-bottom compression strength for most palletized shipments.



## Recommended: Interlocking Stack

If the carton contents are rigid, such as pails of paint, interlocking cartons will result in increased stability. Stack boxes corner-to-corner and edge-to-edge, for better stacking strength.



## NOT RECOMMENDED: Overhanging Stack

Don't overhang the pallet with packaged products, because it can reduce compression strength by as much as 32 percent. Plus it subjects packages to tears, punctures and other impacts due to normal handling and sorting.

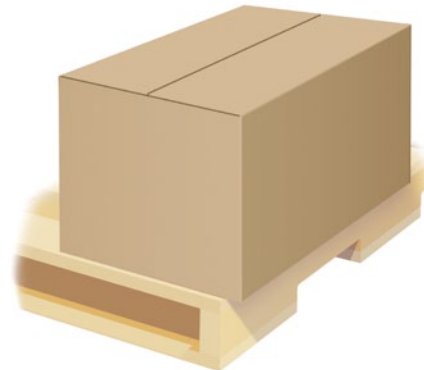

### **NOT RECOMMENDED: Pyramid Stacking**

Space is at a premium, particularly in FedEx Express aircraft, so pyramid stacking is not recommended. More important, pyramid stacks don't provide a level surface, so the top cartons are exposed to potential damage from other shipments. Pallets with a level surface provide better strength and stability for even load and weight distribution when double-stacked.



### **Recommended: Standard Wood Pallets**

FedEx Packaging Services prefers the standard wood pallet developed by the Grocery Manufacturers Association (GMA). It typically measures 40" by 48" and features four-way entry capabilities. The pallet is designed with adequate top board spacing so forklift blades will not impact the freight being shipped. It can be designed to carry heavy or light loads. If you are shipping your goods internationally, some countries require the wood used in pallets or crating to be treated with chemicals or heat to avoid possible pest infestation.

For the latest regulations and information on shipping with wood packaging materials, go to [www.usda.gov](http://www.usda.gov) and enter the search words "wood packaging materials."



### **Recommended: Plastic Pallets**

A viable alternative to wood pallets, plastic pallets are typically more expensive, but they are also reusable. The solid bottom deck often protects the bottom from forklift damage and helps support the load of the products stacked on it. However, the plastic surface is often slippery, which makes fastening or blocking products to prevent movement more difficult. And because plastic pallets weigh more than wood pallets, they may not be the best option if weight is a consideration.



### **NOT RECOMMENDED: Corrugated Pallets**

Because corrugated pallets are lightweight, easily recycled and preferred by some countries that restrict wood pallets, some shippers opt to use them. However, moisture often causes the corrugate to degrade, and side-to-side strength is compromised. They simply do not stand up to the rigors of the transportation environment, so corrugated pallets are not recommended.



### **NOT RECOMMENDED: Wood Pallets Without Bottom Boards**

Because wood pallets without bottom boards don't distribute weight evenly, the stringers can warp or turn in, and side-to-side strength is compromised. These pallets simply do not stand up to the rigors of the transportation environment, so we do not recommend them.



### **NOT RECOMMENDED: Block-Style Pallets**

The block-style pallet is popular in Europe and Asia, and its popularity is growing in the United States. The majority of pallets manufactured in Asia are made from processed wood, which lacks the sturdiness and strength of a natural-wood pallet. This pallet style does not hold up to the rigors of the transportation environment and is not recommended. If you do choose to use this pallet design, make sure it is built to hold the weight of the product, from materials that will make it sturdy and resistant to many touch points in the transportation environment.



### **Wood Crates**

Crating, if constructed properly from quality lumber, can help protect your product. FedEx Packaging Services recommends plywood, not oriented strand board (OSB), medium-density fiberboard (MDF) or particleboard. Knots should be limited, and fasteners should not be anchored in knots or other defective areas of the plywood. Diagonal braces should be used on each panel to increase the strength and integrity of the crate.



### **Crate Corners and Diagonal Bracing**

It's true that diagonal braces can have a dramatic effect on the strength of your crate. But more often than not, the way the wood is used is more important than how much wood is used. When building corners and diagonal braces, avoid weak designs and aim for the stronger constructions shown here.

### **Recommended: Proper Three-Way Corner Construction**

In these examples, the corner construction is strong and rigid because the nails are driven into the side grain, which increases the nail-holding power.



### **NOT RECOMMENDED: Inadequate Three-Way Corner Construction**

In these examples of weak and improper construction, the corners have low nail-holding power because the nails are driven into the end grain.



## Cleated Crate Recommendations

In addition to plywood thickness and cleat stock sizes, fasteners play an important role in maintaining crate strength. From staples to screws, using the proper fastener rated for the weight of the product and crate is key. This chart offers recommendations for appropriate materials based on the weight of your shipment.

NET WEIGHT PART	PANEL SIZE			CLEAT STOCK	CLEAT LENGTHS										FASTENERS						
	THICKNESS	1	2		3	4	5	6	7	8	9	9A	10	PANEL CONSTRUCTION			CONTAINER ASSEMBLY				
		2 REQ.	2 REQ.		2 REQ.	4 REQ.	4 REQ.	4 REQ.	4 REQ.	4 REQ.	4 REQ.	4 REQ.	AS REQ.	NAILS	STAPLES	OTHERS	NAILS	SPACING	STRAP		
0-500	1/4		$(L + 2) \times D$	$(L + 2) \times (W + 2)$	1 x 2	D	W - 3	W + 2	L - 1	L + 2	D - 3	D - 3	W - 1	4 D	1/2 x 1-1/4	1-1/4	x	x	7 D	4	3/4 x .023
	5/16		$(L + 2-1/8) \times D$	$(L + 2-1/8) \times (W + 2-1/8)$				W + 2-1/8	L - 7/8	L + 2-1/8			W - 7/8								
500-800	3/8	W x D	$(L + 2-1/4) \times D$	$(L + 2-1/4) \times (W + 2-1/4)$	1 x 3	D	W - 5	W + 2-1/4	L - 2-3/4	L + 2-1/4	D - 5	D - 5	W - 2-3/4	4 D	16 GAGE	16 GAGE	x	x	7 D	4	3/4 x .023
800-1,000									L - 4-3/4	W - 4-3/4											
WHEN SPECIFIED	1/2		$(L + 2-1/2) \times D$	$(L + 2-1/2) \times (W + 2-1/2)$	1 x 4		W - 7	W + 2-1/2	L - 4-1/2	L + 2-1/2	D - 7	D - 7	W - 4-1/2		1/8 x 1-3/8	1 3/8					

L – Container Length (inside dimension)  
 W – Container Width (inside dimension)  
 D – Container Depth (inside dimension)  
 Note: Chart measurements are in inches.

**Notes:**

- Plywood will conform to exterior-grade plywood.
- Lumber will conform to Class 2 structural. Structural lumber is 2 or more inches in thickness and width for use where working stresses are required.

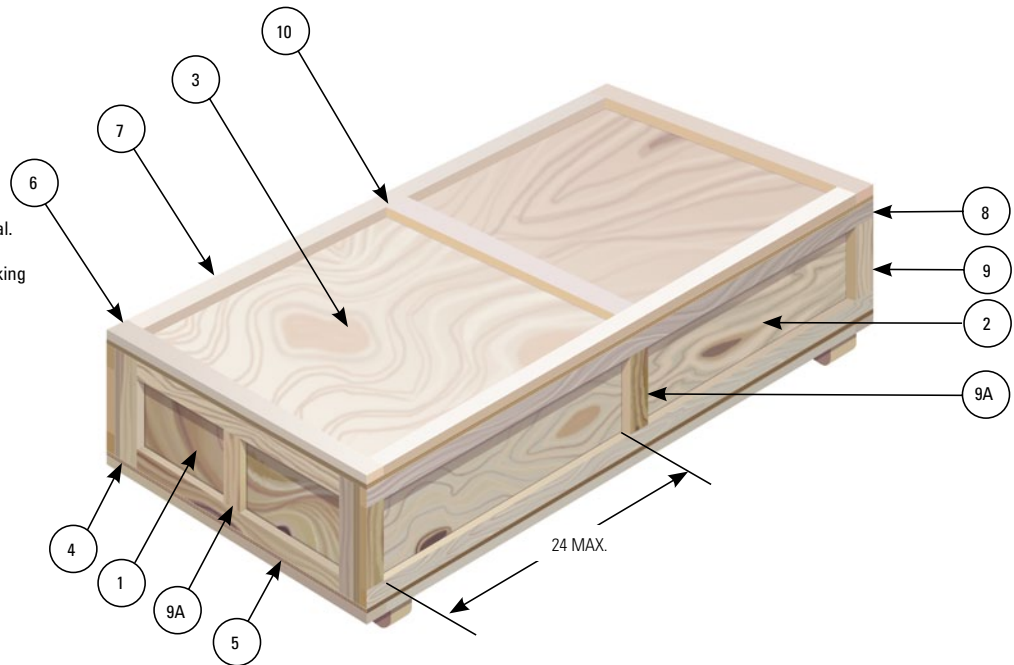

**Grades of Plywood**

Grade	Appearance	Common Use
A	Free of knots; smooth, solid surface	Construction (cabinets)
B	Few knots; sanded, smooth surface	Construction, visible
C	Tight, open knot holes; face splits	Wood crates
D*	Lowest quality; not weather-resistant	Indoor-use construction

\* Not recommended for crate construction.

## Cushioning, Blocking and Bracing

Shock and vibration forces naturally occur during carriage of your goods throughout the shipping process; consequently, most products require some form of cushioning to protect them. Blocking and bracing are also important for larger single-item products that cannot be boxed or crated. To effectively stabilize your shipment, remember to choose the type and size of lumber that's appropriate for the weight of your shipment.

### Foam Cushioning

When developing crates or packaging for your palletized shipments, foam is a natural option for cushioning. As part of the end design, it should be engineered to provide the foam density required to protect the fragility level of the product. It should also be validated through testing that simulates the shipping environment. For FedEx Express shipments, we can help by testing your packaging and making recommendations.

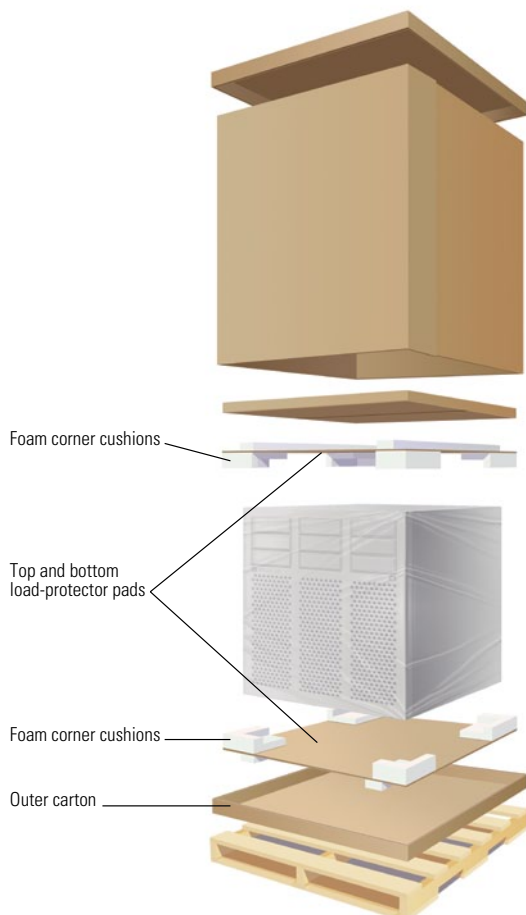

### Wood Blocking

FedEx Packaging Services suggests a blocking material such as wood, fastened to prevent any movement, when shipping single heavy goods. The blocking should be placed tightly against the object with a goal of keeping it in a fixed position during all transportation and handling. As a general rule, blocking requires a minimum of two fasteners in each end to prevent pivoting and maintain adequate strength.

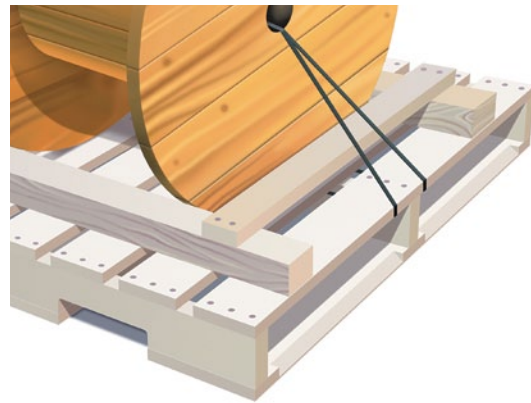

### Bracing

Items that can roll or shift during transportation due to their shape should be braced on a forkliftable pallet base for shipping. These blocking-strength recommendations are critical when it comes to ensuring stationary orientation during shipping. Your selection of lumber should be based on the product that you are bracing and its weight. As the shipping weight increases, the grade and thickness of the bracing lumber should increase. As an example, No. 3 or utility-grade lumber is often used to construct pallets and for bracing materials. However, if the product you are shipping is very heavy, you should choose a better grade of wood, like a No. 1 or No. 2 grade (construction grade), for proper protection.

## Banding and Stretchwrapping

Typically, any damage during transit to palletized corrugated boxes occurs because the shipment was improperly stacked, bundled or secured for transport. This is a particular issue with retail goods such as TVs and DVD players. If there is cosmetic carton damage, the customer is likely to assume the contents are also damaged. As discussed earlier, pallet strength and stacking play an important role in freight shipment integrity. So do load protection, stretchwrapping and banding, which we will cover here.

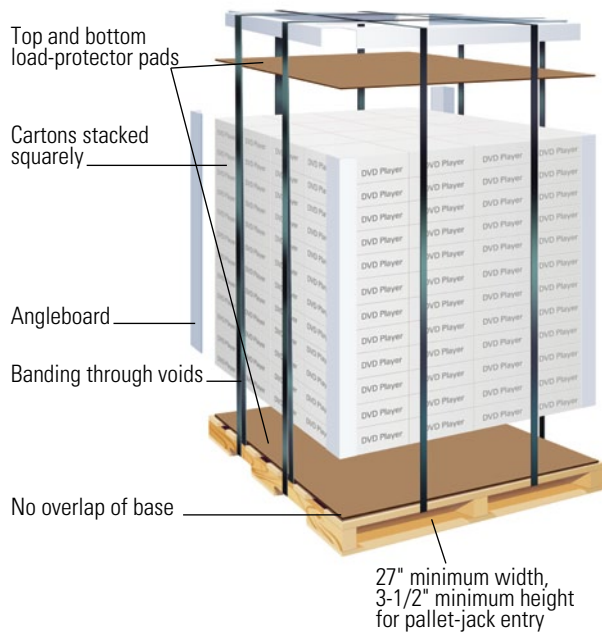

### Load Protectors and Edge Boards

Top and bottom load-protector pads (corrugated pad/tray) help reduce damage to top and bottom layers of your shipment. They also help distribute the weight of top-loaded freight. Bottom load protectors provide a level surface and help keep boxes from slipping into the gap between the boards on the pallet. Corner or edge boards should run the full length of the stack to help stabilize the load, increase vertical stacking strength and reduce damage to box edges that make up the load corners.

## Bands

Banding is typically used to secure the bundled load to the pallet. You should band corrugated stacks on each side as shown. As a general rule, keep the banding close to the load to avoid exposure, damage or breakage. Individual pieces over 150 lbs. and large boxes and containers should be secured on all sides with heavy-duty steel, rayon, polypropylene, nylon or polyester strapping.

## Stretchwrap

Stretchwrap film is critical for bundling loads and also for securing and protecting large individual pieces of freight (e.g., shelf-ready electronic components). Wrap freight tightly to prevent load shifting. Use 70-gauge stretchwrap that sticks to itself so it can be wipe-sealed as it is applied to the stack. When machine wrapping, spiral-wrap the cartons with a minimum 50 percent overlap. Proper application includes a 3" overlap over the top of the pallet base and a 3" overlap at the top of the stack.

To manually apply stretchwrap, tuck the lead wrap between the pallet and the bottom box. Spiral around the boxes in an upward direction, overlapping the film by 50 percent. When you reach the top, stretch the film diagonally over the top corners with a 3" overlap to anchor the stack vertically before spiraling back to the bottom to finish the load with a 3" overlap of the pallet base.



Based on the weight of your shipment, FedEx Packaging Services recommends the following wrap standards.

**Stretchwrap Guidelines**

Weight of Pallet Load	Bottom Wrap* (Includes Pallet)	Top Wrap*
0–500 lbs.	3	2
501–750 lbs.	4	3
751–1,000 lbs.	5	4
1,001–1,500 lbs.	6	6
Over 1,501 lbs.	8	8

\* Wrap indicates layers of stretchwrap film.

**Securing Unique Freight**

Some uniquely shaped items such as tires, bags, drums, spools, transit cases, engines, pipes and copier machines require special handling. FedEx highly recommends that all packaging systems be tested to validate the performance of your design. Improper packaging of these freight shipments can disrupt service, causing damage or delays. We'll explore ways to palletize or crate and secure the shipments here.

**Tires**

Band and stretchwrap a tire or multiple tires to a pallet for freight shipping. FedEx Packaging Services also recommends an anti skid surface for tall stacks to reduce product movement. To complete your shipment, use a tie-on tag or a tire/crate label.

**Aircraft Tire**

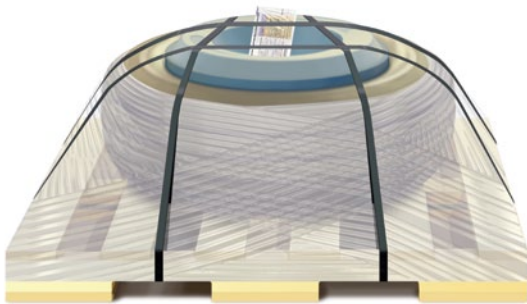

**Truck and Auto Tires**

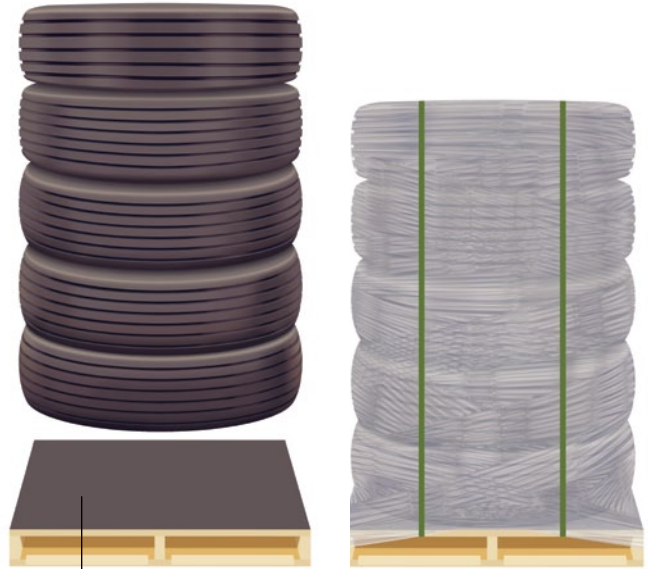

Antiskid surface

**Bags**

Add a solid bottom cushion or load protector (corrugated pad/tray) to help prevent puncture, and use the interlock stacking method to help guard against products shifting during transit. All bags must stay well within the pallet perimeter. Cushion the outside of bags with cardboard when possible.



## Drums

Use the appropriate drum and cap for shipment. Whether you're shipping one or several, drums should be supported by a solid-bottom pallet for shipment. Do not exceed three drums in height or a height of 85" for FedEx Express Freight shipments or 106" for FedEx Freight shipments. And the same basic banding, edge-protection and stretchwrapping recommendations apply to these shipments. However, FedEx Freight allows nonpalletized drum shipments.



FedEx Freight® shipments only

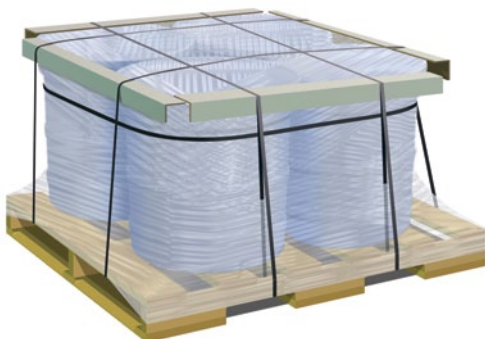

## Spools

Spools and reels tend to roll and shift during transit and are difficult to lift, so they should be secured to a forkliftable pallet. Use blocking and bracing to securely anchor spools and reels.

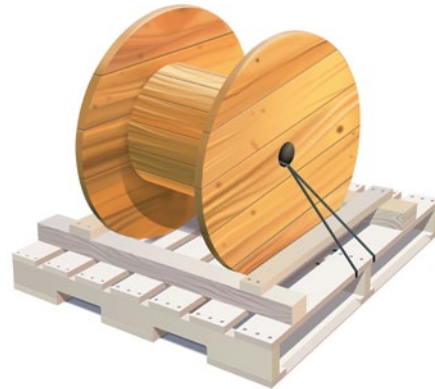

## Transit Cases

If you are shipping transit cases with caster wheels, they must be palletized. Remove the wheels or use traditional blocking methods to prevent movement on the skid. If the wheels are not removed, the pallet deck must be solid to prevent wheels from falling through the slats and being damaged by the forklift. Banding kits are readily available to help you secure your shipment.



Note: If the transit case is locked, bands are not required.

## Engines and Other Exposed Items

Drain the item of all fluids. When using expendable packaging, securely band it to its pallet, and block or brace it inside its corrugated container. Add stretchwrap for additional protection.

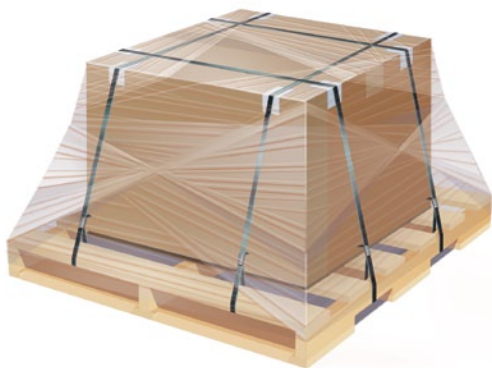
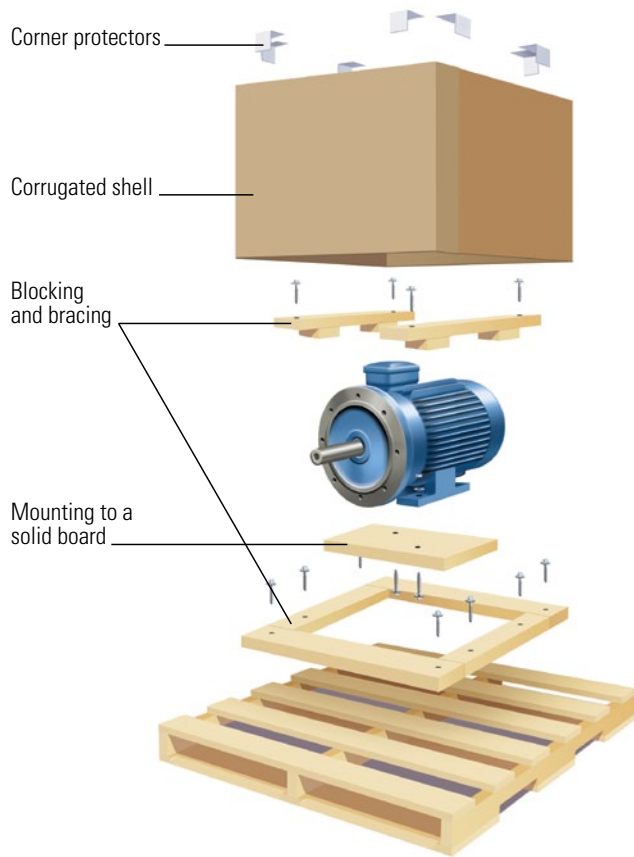

## Pipes and Other Long Freight

When it comes to shipping pipes and other long objects that could cause puncturing or damage to aircraft and trucks, it's important to bundle, secure and crate them for freight shipment. These two designs represent acceptable options for freight shipping because they can be double-stacked, they enable proper handling by mechanical equipment, and labels and paperwork will adhere to the surface.



Reddi Crate® design

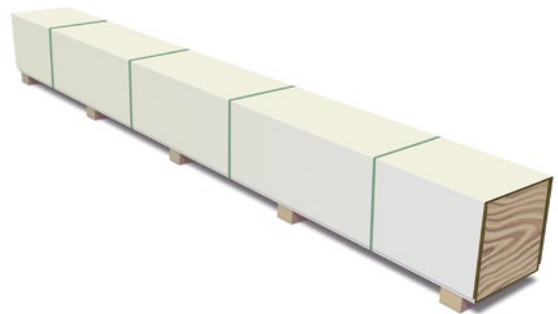

## **NOT RECOMMENDED: Banding and Blocking Pipes and Other Long Freight to a Pallet**

Banding long freight to a pallet is not recommended because it does not provide outer protection for double stacking, there is no blocking on the ends to prohibit side-to-side shifting, and shipping labels will not adhere to the uneven surface.



## Copiers

Start with a properly designed pallet. It's important to ensure that the pallet is compatible with forklifts, pallet jacks and other warehouse lifting devices. Use banding and stretchwrap to securely anchor the copier to the pallet, and keep these basic design parameters in mind:

- **Strength** — Make sure your pallet is strong enough to support the load-carrying weight throughout the shipping and storage environment.
- **Stiffness** — Choose a pallet stiff enough to resist deforming under the load of the copier.
- **Durability** — Select a pallet durable enough to withstand the rigors of the shipping and handling environments, specifically designed with adequate top board spacing so forklift blades will not impact the copier.
- **Functionality** — Utilize only pallets that will function properly with various packaging and material handling equipment.
- **Price** — Balance the price of the pallet with the value of properly supporting the product so it will be delivered without damage to the customer.

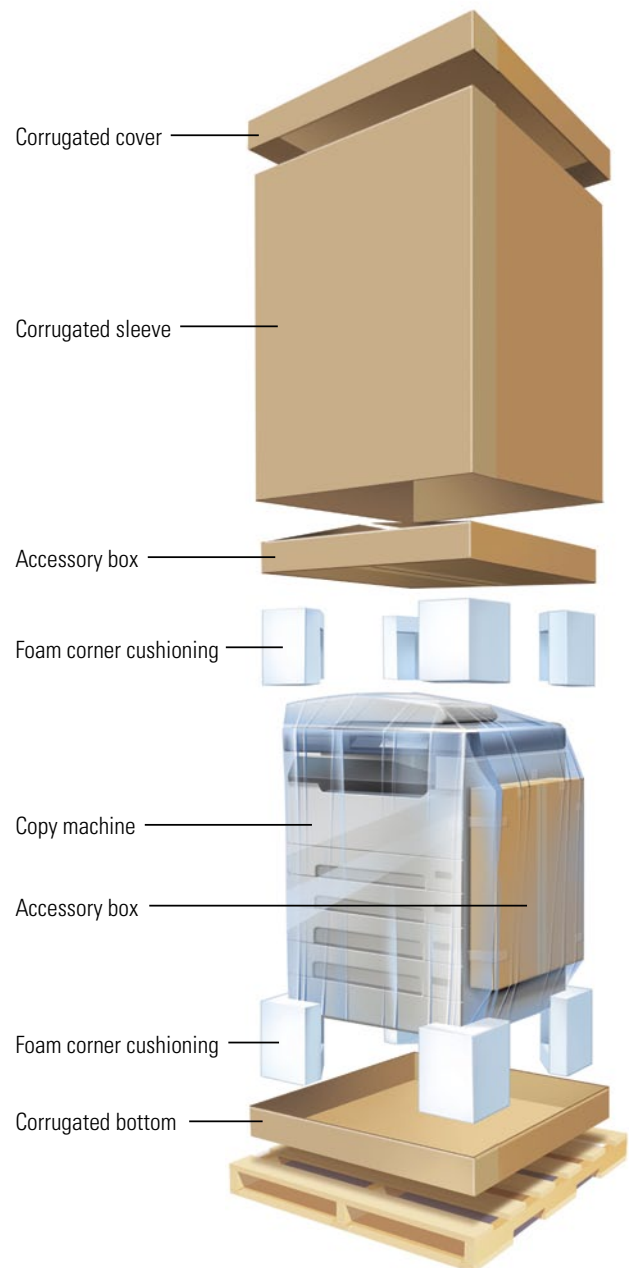

## Marking and Labeling

Handling labels and marking should be clearly visible and positioned on the sides you prefer for forklift entry. Remove or mark out any old labels, tags and markings.

### Marks and Labels

Use descriptive marks or labels to help us identify your shipping requests. Common labels include "This End Up," "Do Not Stack," "Fragile" and "Handle With Care." While we cannot ensure compliance with markings such as up arrows or "This End Up," properly placing the shipping label increases your chance for the preferred orientation. "Do Not Stack" requests cannot always be accommodated, so all freight shipments should be reinforced for stacking.

Although warning stickers can be placed on the outside of the carton, shipping indicators designed to track the shipping environment, such as a shock-watch or tilt-watch meters, should be mounted (with void space) inside cartons to simulate the actual shipping environment and reduce the effects of exterior forces to avoid false readings. They should be applied as recommended by the manufacturer in the proper orientation. You may use these indicators for reference, but neither FedEx Express Freight nor FedEx Freight honors claims exclusively as a result of them. See the applicable terms and conditions for limitations on liability and liabilities not assumed.

## Tire/Crate Labels and Tie-On Tags

FedEx Express offers tire/crate labels designed to be applied to tire treads, but they are also appropriate for crates, plastic-wrapped products, pails, and other applications where a good seal is difficult. The tire/crate label serves as a foundation for your shipping label. It features a strong adhesive to ensure an intact seal during transit, but it comes off in one piece when removed at its destination. For FedEx Express Freight shipments, you can request tire/crate labels, tie-on tags and cable ties at **fedex.com**, or call 1.800.GoFedEx 1.800.463.3339. You may also contact your account executive for supplies.



Tire/Crate Labels



Tie-On Tags



## FedEx Express Freight and FedEx Freight Size and Weight Limits

When choosing your freight service, follow these guidelines to determine if your shipments meet the criteria for acceptable size and weight limits.

CRITERIA	U.S. EXPRESS FREIGHT	INTERNATIONAL EXPRESS FREIGHT	INTERNATIONAL AIR CARGO	FEDEX FREIGHT
	<ul style="list-style-type: none"> <li>FedEx First Overnight® Freight</li> <li>FedEx 1Day® Freight</li> <li>FedEx 2Day® Freight</li> <li>FedEx 3Day® Freight</li> </ul>	<ul style="list-style-type: none"> <li>FedEx International Priority® Freight</li> <li>FedEx International Economy® Freight</li> </ul>	<ul style="list-style-type: none"> <li>FedEx International Premium®</li> <li>FedEx International Express Freight®</li> <li>FedEx International Airport-to-Airport<sup>SM</sup></li> </ul>	<ul style="list-style-type: none"> <li>FedEx Freight® Priority</li> <li>FedEx Freight® Economy</li> </ul>
<b>Minimum weight per piece (skid) or shipment</b>	151 lbs. (68 kg) <sup>1,3</sup>	151 lbs. (68 kg) <sup>1,4</sup>	No minimum restrictions <sup>5</sup>	No minimum restrictions <sup>6</sup>
<b>Maximum weight per piece (skid)</b>	2,200 lbs. (997 kg) <sup>2</sup>	2,200 lbs. (997 kg) <sup>2</sup>	2,200 lbs. (997 kg) <sup>2</sup>	3,150 lbs. (1,429 kg) <sup>2,5</sup>
<b>Maximum weight per shipment</b>	Unlimited	Unlimited	Unlimited	20,000 lbs. (9,072 kg) <sup>2</sup>
<b>Maximum length per piece (skid)</b>	119" (302 cm) <sup>2</sup>	119" (302 cm) <sup>2</sup>	119" (302 cm) <sup>2</sup>	24' (7 m) <sup>2</sup>
<b>Maximum height per piece (skid)</b>	70" (178 cm) <sup>2</sup>	70" (178 cm) <sup>2</sup>	70" (178 cm) <sup>2</sup>	106" (269 cm) <sup>2</sup>
<b>Maximum width per piece (skid)</b>	80" (203 cm) <sup>2</sup>	80" (203 cm) <sup>2</sup>	80" (203 cm) <sup>2</sup>	93" (236 cm) <sup>2</sup>

<sup>1</sup> Minimum billable weight is 151 lbs. regardless of actual weight.

<sup>2</sup> Pieces (skids) or shipments exceeding the maximum size and weight exceptions require prior approval from FedEx Express Freight Customer Service at 1.800.332.0807 or FedEx Freight Customer Service at 1.866.393.4585.

<sup>3</sup> Pieces weighing less than 151 lbs. that exceed 165" in length and girth combined ("extra-large" packages) may be accepted as FedEx Express® Freight U.S. shipments. These pieces do not have to be palletized (skidded), stackable or forkliftable. See the current FedEx Service Guide for more information.

<sup>4</sup> Unskidded pieces less than 151 lbs. (68 kg) can be accepted as FedEx International Priority Freight or FedEx International Economy Freight only if the length plus girth exceeds 130" (called Extra Large Package) and are subject to a billable weight of 151 lbs.

<sup>5</sup> Based on weight being evenly distributed on a standard skid.

<sup>6</sup> Another FedEx® service may be better suited for shipments less than 151 lbs. (68 kg).

## Contacts and Resources

- FedEx Freight packaging essentials and tips, [fedex.com/packagingfreight](http://fedex.com/packagingfreight).
- FedEx Packaging Design and Development, [packagingservices@fedex.com](mailto:packagingservices@fedex.com) or 1.800.633.7019.
- FedEx Service Guide at [fedex.com/us/services](http://fedex.com/us/services) for terms and conditions governing FedEx Express Freight and FedEx Freight shipments.
- FedEx Express Freight Customer Service, 1.800.332.0807.
- FedEx Freight Customer Service, 1.866.393.4585.
- [www.usda.gov](http://www.usda.gov); enter search words “wood packaging materials.”

**NOTICE:** This packaging brochure is provided free to FedEx customers to help reduce loss or damage due to improper packaging. It is NOT intended to be a comprehensive guide for packaging items we accept for transit. We make no warranties, expressed or implied, regarding this information. Proper packaging is the sole responsibility of the shipper. For more information and additional guidelines, go to the packaging tips page on [fedex.com/packagingfreight](http://fedex.com/packagingfreight), email [packagingservices@fedex.com](mailto:packagingservices@fedex.com), or contact FedEx Packaging Design and Development at 1.800.633.7019. Refer to the current FedEx Service Guide for terms, conditions and limitations applicable to FedEx® delivery services.

© 2012 FedEx. All rights reserved.

0004294CP-Rev. 4/12