



## Automotive and Mechanical Parts Packaging Guidelines and Designs

Responsible packaging can save you money and improve the safety and handling of your shipments. Follow these tips and design recommendations.



## General Guidelines

- Pad all sharp edges, corners and burrs of parts such as sheet metal or bare metal.
- Pad or cover precision-machined areas of parts, such as threads and fittings.
- Protect all parts that are susceptible to damage due to dents, scratches, and scuffing by using an appropriate amount of cushioning material and placing in a sturdy shipping container.
- Place documentation and shipping or routing labels on flat surfaces that will allow for maximum adhesion. Avoid placing labels around curved surfaces.
- Place all labels on the side with the largest surface area.
- Use FedEx tie-on tags, tire/crate labels, or plastic air waybill pouches instead of wire tags.

## Automotive Parts Best Practices

- Ship engines, motors, transmissions, and chassis parts via FedEx Express® or FedEx Freight® services.
- Drain and empty parts filled with lubricant fluids before shipping or demonstrate that the shipment is leakproof under all orientations.
- Help reduce damages and ensure safe working conditions for handlers by adequately packaging all mechanical or automotive parts.

## Shipping Methods and Minimum Packaging Requirements

You are responsible for proper packaging when shipping; these tips should be helpful when packaging specific items. If items are not fully encased in an outside shipping container, an additional handling surcharge may apply. For complete terms and conditions, see the current FedEx Service Guide at [fedex.ca](http://fedex.ca).

FedEx may reject any parts packaging that does not meet the minimum shipping standards for acceptance.

## Shipping in Corrugated Boxes

When packaging parts, use adequate dunnage such as loosefill peanuts or other padding material to fill void spaces and prevent movement inside the box.

### Wheels

Cushion the entire surface, and box chrome, painted, and decorative wheels that are susceptible to damage as a result of scratches or scuffing. Wrap non-decorative wheels in adequately taped clear plastic liner.

### Flexplates, Flywheels

Pack flexplates and flywheels with adequate dunnage such as loosefill peanuts to fill void spaces in double- or triple-wall corrugated boxes, depending on the weight of the part. Apply “heavy” labels to boxes exceeding 75 lbs. (34 kg).

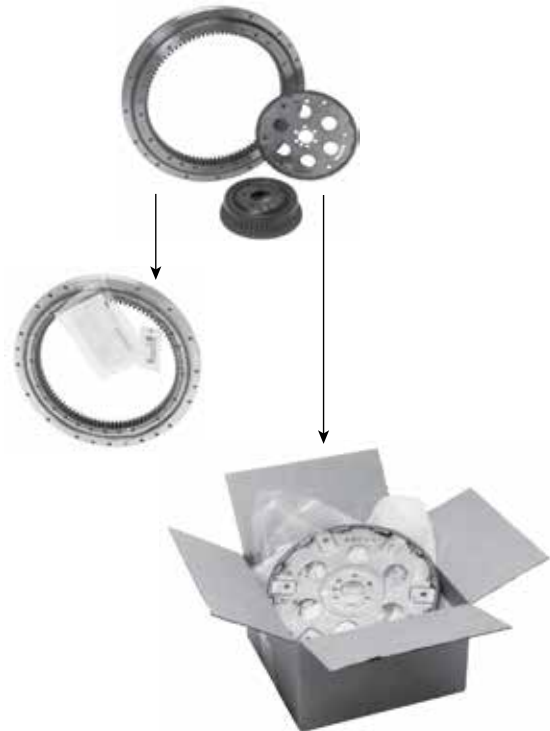

### Car Doors, Hoods, Panels

Cushion and box all exposed metallic surfaces that are susceptible to damage as a result of scratches or dents.

## Decorative Parts

Cushion and box all decorative parts such as grills that may be unusable as a result of scratches, dents, bending, or scuffing.

## Flexible Plastic Moulding

Cushion and box all flexible plastic moulding to prevent breakage or tearing.

Pad and cover protruding parts that might break or puncture the box.

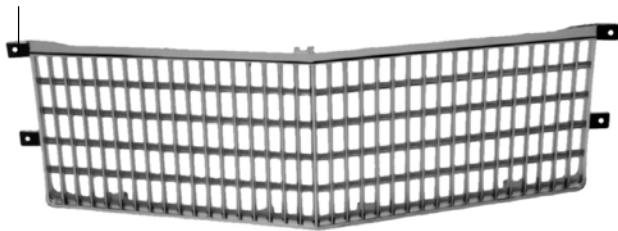

## Shocks, Coil Springs

Box cylindrical parts that can be packaged in tubes with adequate dunnage such as padding at the ends and loosefill peanuts to prevent puncturing through the end closures. Tag coil springs with a FedEx tie-on tag and adhere the shipping label to the tie-on tag if the item cannot be packaged in a tube or corrugated box.

## Bumpers

Box bumpers that are susceptible to scratches or dents. Or wrap bumpers in adequately taped heavy-duty plastic bags and padding to protect any sharp or pointed corners.

## Shipping With Secure Wrapping and Padding

When preparing irregular-shaped parts for shipment, tape cushioning material securely to help prevent removal during the handling process. We recommend placing the parts in a box in addition to the minimum requirements shown.

## Moulding

Wrap non-decorative plastic moulding in adequately taped plastic film or bags, or cushion and box them.



## Sway Bars, A-Arms

Wrap sway bars, A-arms, and threaded rods in fibreboard or appropriate plastic film or bags and tape securely.



## Exhaust System Parts, Leaf Springs

Pad and cover pointed and sharp edges with corrugated boards, adequate foam, or air-cellular cushioning material such as Bubble Wrap® and tape securely.



## Tires

Place the tire/crate label on the tread of the tire and apply the FedEx shipping label on top of the tire/crate label.



## Shipping With a Forkliftable Base

Secure transmissions and other parts weighing more than 150 lbs. (68 kg) to a forkliftable base compatible with pallet-jack usage. Banding to a pallet or bracing inside a corrugated container helps prevent damage in handling. For information on shipping freight, see “Packaging Freight Shipments.”

## Transmissions, Engines

Drain the transmission of all fluids and place it in a plastic bag with absorbent padding below to absorb any residual fluid. When using expendable packaging, securely band it to its pallet, or block or brace it inside its corrugated container. If you use a reusable container, secure the transmission to the base with strapping. All forkliftable bases for engines and transmissions must be shipped only by FedEx Express® Freight or FedEx Freight services.

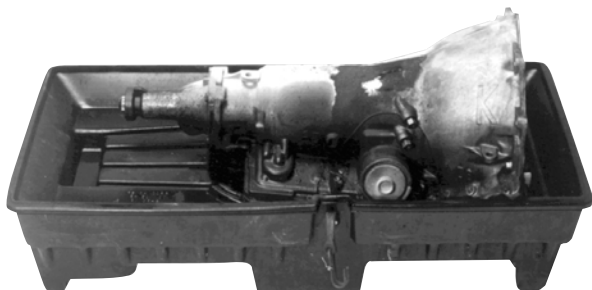

## Dangerous Goods/Hazardous Materials Guidelines

Some of the most frequently shipped automotive and mechanical parts and accessories may be considered dangerous goods and hazardous materials. These include airbags, aerosols (some examples include paint and lubricants), batteries, engines and engine blocks with hazardous fuel, used fuel tanks, flammable paints, and touch-up paints.

Check with the manufacturer for the Safety Data Sheet (SDS) for detailed information on the product. The shipper is responsible for correctly identifying, classifying, packaging, marking, labelling, and completing documentation for dangerous goods and hazardous materials. Transport Canada requires shippers to have job-specific dangerous goods training prior to tendering dangerous goods to FedEx or another air carrier. Reference the Transportation of Dangerous Goods Regulations Part 6 for complete details.

FedEx Express may be required by law to report improperly declared or undeclared shipments of dangerous goods to authorities. The shipper may be subject to fines and penalties under applicable law. Questions may be directed to the FedEx Dangerous Goods Hotline; call 1.800.GoFedEx 1.800.463.3339 press “81” or say “dangerous goods.”

## Common Designs for Automotive Parts

### Flat-Style Hood Design

Corrugated rear roll-up pad  
(275# BC flute)

Roll-up slit-cut pad  
(275# C flute)

Nose roll-up pad  
(275# BC flute)

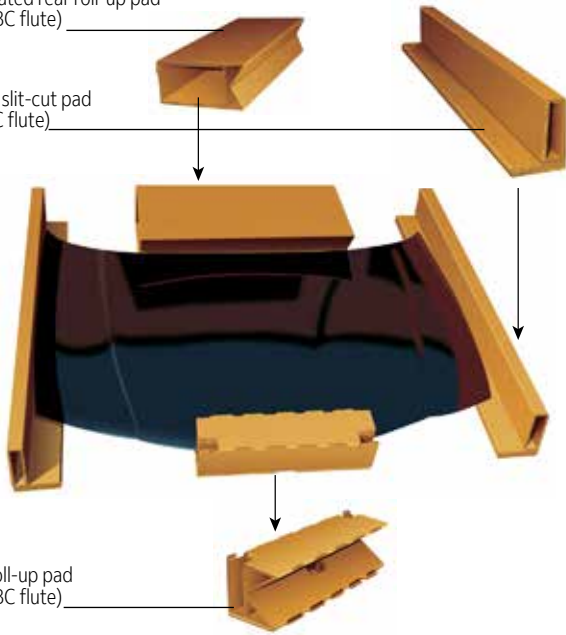

With this design, you centre the nose and rear roll-up pads and staple them to the inner flaps of the end-loaded full-overlap shipping container. Place the hood in the container followed by roll-up slit-cut pads. Close and tape.

Hood and cushioning are placed inside a 275# BC flute full-overlap corrugated shipping container before shipping.

### Grill-Style Hood Design

Corrugated rear roll-up pad  
(275# BC flute)

Corrugated side rail  
(275# C flute)

Plastic pads  
adhered to  
corrugated roll-up



This design incorporates side rails to elevate and suspend the hood. The air space created by the elevation helps protect the grill from external forces

Before shipment, place the hood and cushioning inside a 275# BC flute full-telescope corrugated shipping container for protection and stability.

### Overbox-Style Hood Design

Moulded inserts

Corrugated  
outer container  
(275# BC flute)



This design uses moulded pulp inserts on all four class A sides of the inner container to help provide cushioning.

Before shipment, place the hood and cushioning inside a 275# BC flute corrugated shipping container for support and protection.

### Trunk-Pack Design

Moulded inserts

Corrugated tube  
(275# BC flute)

Corrugated roll-up  
(275# BC flute)

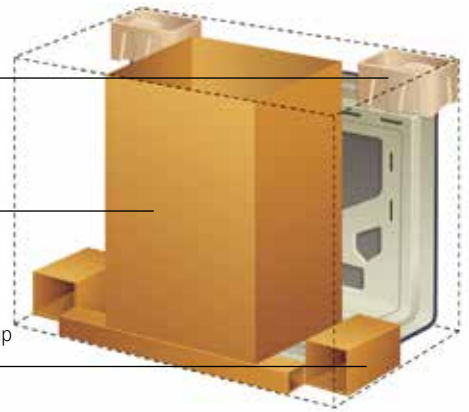

This design helps protect the trunk pack from external forces. Moulded inserts are used to create air cells and brace the trunk lid.

Once the inserts are in place, place both the trunk lid and cushioning inside a 275# BC flute full-overlap corrugated shipping container for protection.

**Door-Pack Design**

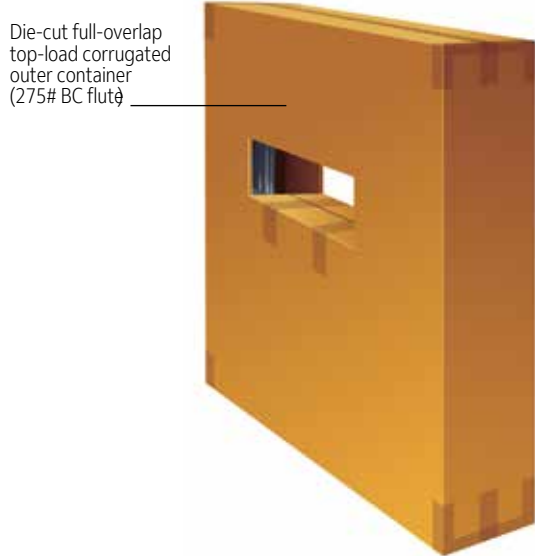
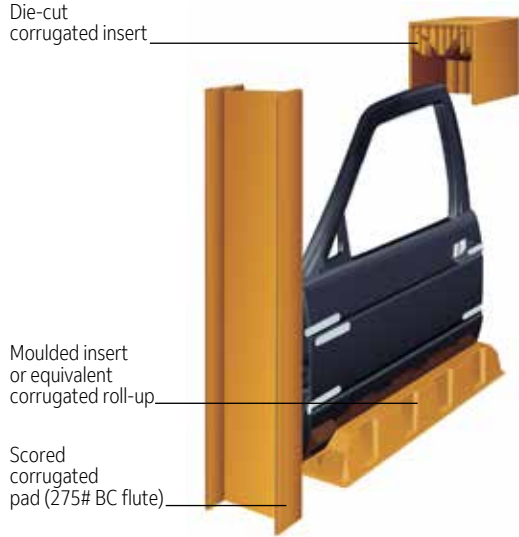

This design combines the use of a scored pad, a die-cut corrugated insert, and a moulded insert to help provide cushioning and bracing of the door inside the outer shipping container.

Once roll-ups and pads are attached to the door, place both the door and cushioning inside a 275# BC flute corrugated shipping container for protection.

**Windshield-Pack Design**

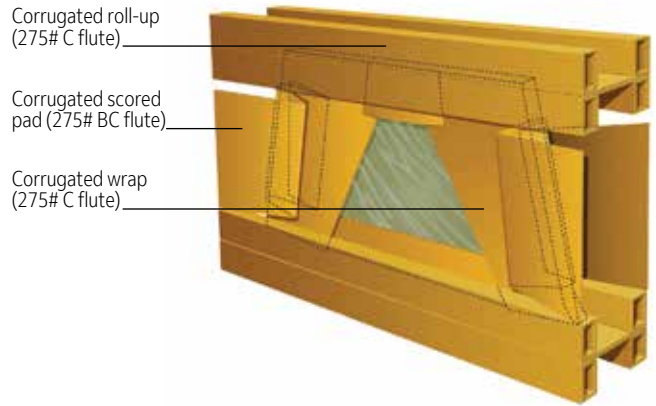

This design helps protect windshields from shock and/or torque during transit. The wrap converts a non-rigid part into a rigid surface so it can be cushioned and braced off of the corrugated wrap.

Before shipment, place the windshield and cushioning inside a full-overlap 275# BC flute corrugated shipping container.

**Rim-Pack Design**

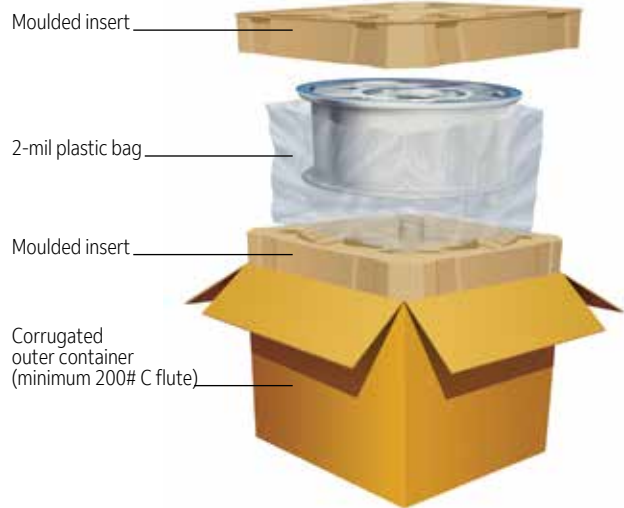

This design protects the rim from dents, scratches and abrasions. The moulded inserts are designed to fit multiple sizes.



### Fascia- (Bumper Cover) Pack Design

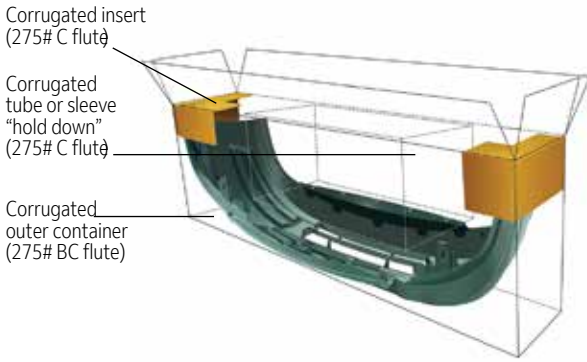

This design protects the fascia from scratches and abrasions. Additional poly-bag surface protection is optional.

Before shipping, place the fascia inside a 275# BC flute corrugated full-overlap shipping container. Then place inserts and the tube or sleeve into position.

### Trim or Moulding Pack Design



This rigid outer package design protects the pre-paint trim or moulding from scratches and bending

Trim Sonopost to fit the part length. Insert the covered trim or moulding into the corrugated outer container and tape both ends with minimum 2"-wide pressure-sensitive plastic tape.

## Packaging Freight Shipments

Shipments that qualify as freight must be packaged accordingly. See the current FedEx Service Guide at [fedex.ca](http://fedex.ca) to determine if your shipment qualifies as freight.

You must package your freight shipments to allow for stacking of other packages on top of your shipment. Make sure your freight shipments are banded and stretchwrapped to the pallet, with the bands running in both directions. (Pallet loads secured with only stretchwrap are not acceptable.)

Avoid corrugated or fibreboard pallets. You must secure all freight shipments weighing 151 lbs. (69 kg) or more on a forkliftable base, compatible for pallet-jack usage. The minimum specifications for a typical base for forklift or pallet-jack configuration are illustrated here.

### FedEx Express Freight Shipments

To lessen the possibility of damage or delay to your cargo, make sure that all single-piece cargo greater than 150 lbs. (68 kg) is banded on all sides with heavy-duty metal or break-resistant plastic banding.

- FedEx Express Freight shipments must be on a pallet, skid, or other forkliftable and pallet-jackable base with a minimum clearance of 3-1/2" (9 cm) for access, and should be stackable.

### Minimum Freight Specifications, Typical Base, Forklift or Pallet-Jack Configuration

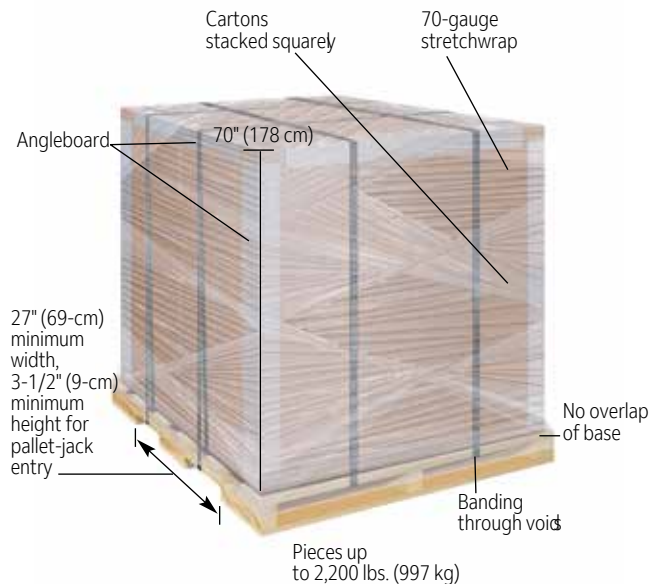

- Single pieces of cargo weighing more than 150 lbs. (68 kg) must be banded and stretchwrapped to a pallet or skid. The banding material must be heavy-duty metal or break-resistant plastic, and the cargo must be banded to the pallet or skid on all sides.
- Non-banded single pieces of cargo weighing more than 150 lbs. (68 kg) must be encased in a hard container (e.g., plywood or metal) and secured with an exterior lock or clamp. Please note that containers secured with glue, nails, and screws without an exterior lock or clamp are not acceptable.

## Contacts and Resources

- *How to Pack* guidelines at [fedex.ca/packaging](https://www.fedex.ca/packaging).
- To request your package testing or evaluation, please contact your FedEx account executive.
- FedEx Dangerous Goods Hotline, 1.800.GoFedEx 1.800.463.3339; press “81” or say “dangerous goods.”

## Sealing and Labelling Instructions

- When sealing corrugated outer containers, apply at least three strips of pressure-sensitive adhesive plastic tape that is at least 2" (5 cm) wide to both the top and bottom of the carton.

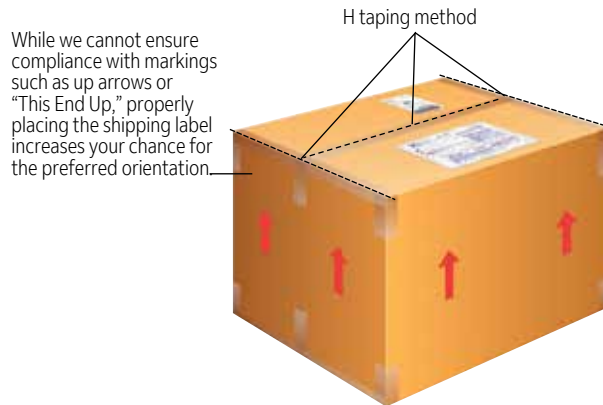

- Tape all seams or flaps using the H taping method.
- Place the shipping label on the top of the largest side.
- When shipping parts that cannot be packaged in corrugated outer containers, tag them appropriately.
- Tag wrapped and padded parts with a FedEx tie-on tag and adhere the shipping label to the tie-on tag.
- Request tie-on tags, cable ties or tire/crate labels at [fedex.ca](https://www.fedex.ca) or call 1.800.GoFedEx 1.800.463.3339.

Bubble Wrap is a registered trademark of Sealed Air Corporation. Sonopost is a registered trademark of Sonoco Products Company.

**NOTICE:** This packaging brochure is provided to FedEx customers to help reduce loss or damage due to improper packaging. It is NOT intended to be a comprehensive guide for packaging items we accept for transit. We make no warranties, expressed or implied, regarding this information. Proper packaging is the sole responsibility of the shipper. For more information and additional guidelines, see the packaging tips page at [fedex.ca/packaging](https://www.fedex.ca/packaging). Refer to the current FedEx Service Guide at [fedex.ca](https://www.fedex.ca) for terms, conditions and limitations applicable to FedEx® delivery services.  
© 2019 FedEx. All rights reserved.