



## Packaging Guidelines for Shipping Freight

At FedEx, we know proper packaging of your freight is the best way to ensure that your goods arrive safely at their destination. So we offer these guidelines for shipments weighing more than 150 lbs.



## Contents

The words skid and pallet may be used interchangeably in this document. However, a skid is defined as a handling platform without bottom deck boards, and a pallet is defined as a handling platform with bottom deck boards. Based on durability, integrity and handling efficiency, the FedEx shipping networks recommend the use of pallets versus skids.

Shipping and Handling Considerations	3
Pallets and Stacking	4
Wood Crates	7
Cushioning, Blocking and Bracing	9
Banding and Stretchwrapping	9
Securing Unique Freight	11
Marking and Labeling	15
Contacts and Resources	17



## FedEx Guidelines for Shipments Weighing More Than 150 Lbs.

Start with an understanding of the FedEx Express and FedEx Freight shipping conditions and proceed to the specific guidelines and requirements for palletizing and preparing your freight shipments.

### Shipping and Handling Considerations

When it comes to shipping freight, size, weight, climate and general handling issues come into play because often it takes multiple vehicles to deliver your goods to their final destination. FedEx Express Freight (Air) and FedEx Freight (LTL and Over the Road) share freight-packaging guidelines and requirements with some exceptions. For specific terms and conditions governing FedEx Express® Freight and FedEx Freight® shipments, go to [fedex.com/us/services](https://www.fedex.com/us/services).

#### FedEx Express Freight



#### FedEx Freight



### Size, Weight and Climate: FedEx Express Freight

FedEx Express Freight shipments must be on a pallet, skid or other forkliftable and pallet-jackable base with a minimum clearance of 3-1/2" for access, and should be stackable. A surcharge applies to any piece, skid or pallet of a FedEx Express freight shipment that is non-stackable. For details on the surcharge, please see the Rates and Surcharges section of the FedEx Service Guide at [fedex.com](https://www.fedex.com).

Depending on the size and shape of product, four-way pallet or skid entry is recommended. You may ship individual units of 151 lbs. or more. Skids exceeding 2,200 lbs. require prior approval. Total shipment weight is unlimited. Skids measuring in excess of 70" high or 119" long or 80" wide require prior approval.

Individual pieces over 150 lbs. should be banded to the pallet with either metal strapping or unbreakable plastic straps applied over the box or skid freight on all sides.

Hardened containers (plywood, metal) that are not banded should have an exterior lock or clamp. (Glue, nails and screws are not sufficient.)

Take a look at our FedEx Express freight air cargo compartments and standard distribution and delivery truck dimensions, and you'll see why we have specific size recommendations for freight shipments.

On board FedEx Express® aircraft, temperatures vary depending on the type of aircraft, the location of each cargo compartment and the package location within each compartment, the length of flight and the cruising altitude. For general reference, temperatures aboard most wide-body aircraft main cargo compartments vary between 40° F (5° C) and 85° F (30° C). Packages positioned in the bulk department, next to the aircraft's outer structure, might be exposed to temperatures as low as 35° F (2° C) during flight, but could be subjected to temperatures as low as 20° F (-7° C) during international flights.

Air pressures on FedEx Express aircraft vary from as low as 8.3 psi at cruise altitude to as much as 14.7 psi on the ground.

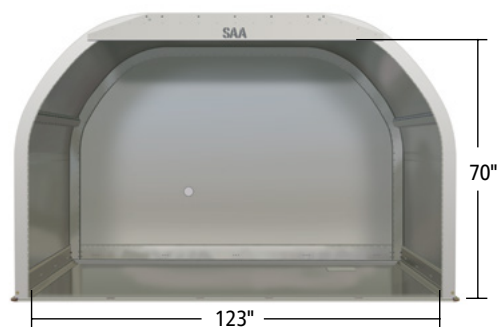

Our SAA cargo carrier measures 70"H x 123"W x 88"D.

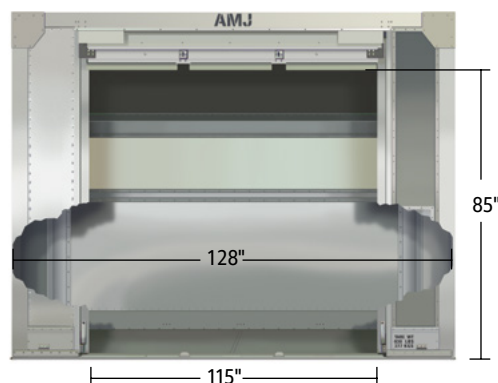

Based on door entry, our AMJ cargo carrier measures 85"H x 128"W x 88"D.

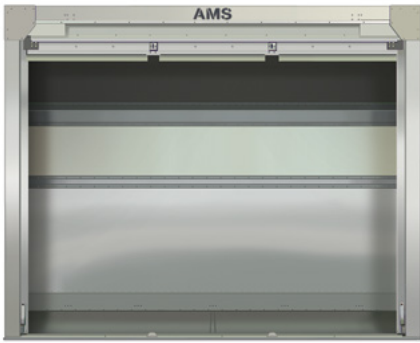

Our AMS cargo carrier measures 108"H x 125"W x 96"D.



## FedEx Freight

FedEx Freight shipments may be palletized or nonpalletized, weigh up to 20,000 lbs. (no individual piece or pallet greater than 3,150 pounds) and measure up to 20 feet in length. The use of a pallet or handling base in LTL shipments is preferred for handling efficiency and safety, to reduce product damage and to maintain package orientation.

The cargo areas of our trucks are not temperature-controlled, and temperature will vary depending on time of year, location, exposure to sunlight and other variables. In summer months, the temperature in the cargo area can be as much as 30 degrees higher than the ambient temperature outside the vehicle.

### Compression, Shock and Vibration: FedEx Express Freight and FedEx Freight

Your freight shipment will likely face forklifts, conveyor belts, double stacking and multiple transport vehicles along its way to its final destination, so in addition to size, weight and climate recommendations, proper packaging also helps cushion goods to withstand ordinary care in handling.

## Pallets and Stacking

The orientation of cartons in your palletized freight shipments can have a big impact on the integrity of your shipments. The FedEx Packaging Lab suggests that you adhere to the following guidelines. You'll find examples of appropriate options for palletized freight shipping and some common — but not advisable — practices. Plus you'll get practical suggestions for manufacturing pallets and crating materials.

### Recommended: Column Stack

Column-stack loads for palletized freight. In almost all cases it increases the top-to-bottom compression strength for most palletized shipments.



### Recommended: Interlocking Stack

If the carton contents are rigid, interlocking cartons will result in increased stability. Stack boxes corner-to-corner and edge-to-edge, for better stacking strength.



### NOT RECOMMENDED: Overhanging Stack

Don't overhang the pallet edges with packaged products, because it can reduce package compression strength by as much as 32 percent. Plus it subjects packages to tears, punctures and other impacts during normal handling and sorting.

Freight overhanging or extending beyond the pallet perimeter may be damaged during handling or damaged by adjacent freight. Claims resulting from improper stacking or load shifting may not be honored.

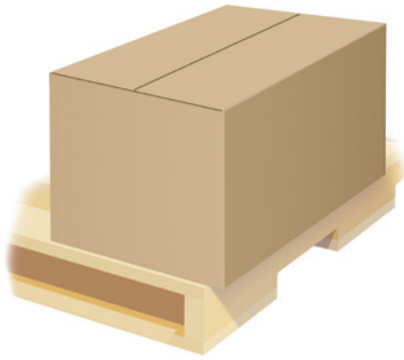

### **NOT RECOMMENDED: Pyramid Stacking**

Space is at a premium, particularly in FedEx Express aircraft, so package stacking will likely occur, and pyramid stacking is not recommended. More important, pyramid stacks don't provide a level surface, so the top cartons are exposed to potential damage from other shipments. Units with a level top surface provide better strength and stability for even load and weight distribution when double-stacked.



### **Pallet Design Considerations**

One of the key benefits of a four-way entry pallet is the ease with which it can be moved into trailers and air cargo containers. Keep these basic design parameters in mind:

- **Strength** — Make sure your pallet is strong enough to support the load-carrying weight throughout the shipping and storage environment.
- **Stiffness** — Choose a pallet stiff enough to resist deforming under the load.

- **Durability** — Select a pallet durable enough to withstand the rigors of the shipping and handling environments, specifically designed with adequate top board spacing so forklift blades will not impact the product.
- **Functionality** — Utilize only pallets that will function properly with various packaging and material handling equipment.
- **Price** — Balance the price of the pallet with the value of the product, while properly supporting the load so it can be delivered without damage to the customer.

### **Recommended: Standard Wood Pallets**

The FedEx Packaging Lab prefers the standard wood pallet developed by the Grocery Manufacturers Association (GMA) now referred to as the Consumer Brands Association (CBA). It typically measures 40" by 48" and features four-way entry capabilities. The pallet is designed with adequate top board spacing so forklift blades will not impact the freight being shipped. It can be designed to carry heavy or light loads. If you are shipping your goods internationally, some countries require the wood used in pallets or crating to be treated with chemicals or heat to avoid possible pest infestation.

For the latest regulations and information on shipping with wood packaging materials, go to [www.usda.gov](http://www.usda.gov) and enter the search words "wood packaging materials."

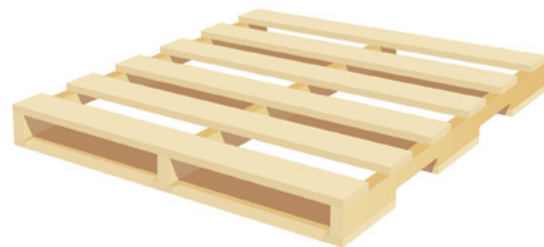

A new pallet is recommended versus a damaged or repaired pallet. The pallet should be designed to support the packaged product load and withstand the rigors of the shipping environment. A damaged or repaired pallet, though cost-effective, has an unknown integrity, and its quality and strength is only as good as the repair. Reused pallets and crates should be monitored for use and excessive degradation over time.

### **Recommended: Plastic Pallets**

A viable alternative to wood pallets, plastic pallets are typically more expensive, but they are also reusable. The solid deck often protects the package bottom from forklift tine damage and helps support the load of the products stacked on it. However, the plastic surface is often slippery, which makes fastening or blocking products to prevent movement more difficult. Some plastic pallets can weigh more than wood pallets, and they may not be the best option if weight is a consideration.



### **NOT RECOMMENDED: Pressed Block-Style Pallets and Molded Pulp Pallets**

Pressed Block-style and molded pulp pallets are popular in Europe and Asia, and their popularity is growing in the United States. Most pallets manufactured in Asia are made from processed wood, which lacks the sturdiness and strength of a natural-wood pallet. These pallet styles do not hold up to the rigors of the transportation environment and are not recommended. If you do choose to use these pallet designs, make sure they are built to hold the weight of the product, from materials that will make them sturdy and resistant to many touch points in the transportation environment.

### **NOT RECOMMENDED: Corrugated Pallets**

Because corrugated pallets are lightweight, easily recycled and preferred by some countries that restrict wood pallets, some shippers opt to use them. However, paper-based pallets are easily damaged, and moisture often causes the corrugate to degrade. They simply do not withstand the rigors of the transportation environment, so corrugated pallets are not recommended.

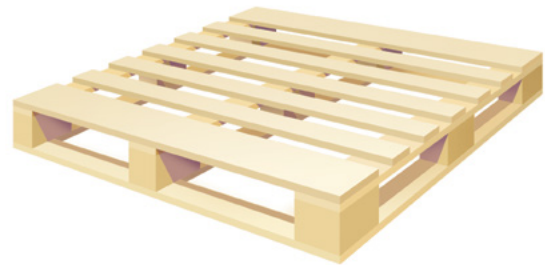

### **NOT RECOMMENDED: Wood Pallets Without Bottom Boards (“Skids”)**

Because wood pallets without bottom boards (commonly known as “skids”) don’t distribute weight evenly, they can be challenging to lift and the stringers are easily compromised or damaged. This style of pallet simply does not stand up to the rigors of the transportation environment, and we do not recommend them.



## Wood Crates

Crating, if constructed properly from quality lumber, can help protect your product. The FedEx Packaging Lab recommends plywood, not oriented strand board (OSB), medium-density fiberboard (MDF) or particleboard. Knots should be limited, and fasteners should not be anchored in knots or other defective areas of the plywood. Diagonal braces should be used on each panel to increase the strength and integrity of the crate.



### Crate Corners and Diagonal Bracing

It's true that diagonal braces can have a dramatic effect on the strength of your crate. But more often than not, the way the wood is assembled is more important than how much wood is used. When building corners and diagonal braces, avoid weak designs and aim for the stronger constructions shown here.

#### Recommended: Proper Three-Way Corner Construction

In these examples, the corner construction is strong and rigid because the nails are driven into the side grain, which increases the nail-holding strength.



#### NOT RECOMMENDED: Inadequate Three-Way Corner Construction

In these examples of weak and improper construction, the corners have low nail-holding strength because the nails are driven into the end grain.



### Fasteners

OK—Rectangular Wire Staple



Good—Helically Threaded Nail



Better—Annularly Threaded Nail



Best—Wood Screws



Use the appropriate fastener and wood material sizes to resist splitting or fracturing the wood components during assembly.

## Cleated Crate Recommendations

In addition to plywood thickness and cleat stock sizes, fasteners play an important role in maintaining crate strength. From staples to screws, using the proper fastener rated for the weight of the product and crate is key. This chart offers recommendations for appropriate materials based on the weight of your shipment.

NET WEIGHT PART	PANEL SIZE			CLEAT STOCK	CLEAT LENGTHS										FASTENERS						
	THICKNESS	1	2		3	4	5	6	7	8	9	9A	10	PANEL CONSTRUCTION			CONTAINER ASSEMBLY				
		2 REQ.	2 REQ.		2 REQ.	4 REQ.	4 REQ.	4 REQ.	4 REQ.	4 REQ.	4 REQ.	AS REQ.	NAILS	STAPLES	OTHERS	NAILS	SPACING	STRAP			
0-500	1/4	W x D	$(L + 2) \times D$	$(L + 2) \times (W + 2)$	1 x 2	D	W - 3	W + 2	L - 1	L + 2	D - 3	D - 3	W - 1	4 D	1/2 x 1-1/4	x	16 GAGE	16 GAGE	7 D	4	3/4 x .023
	5/16		$(L + 2-1/8) \times D$	$(L + 2-1/8) \times (W + 2-1/8)$				W + 2-1/8	L - 7/8	L + 2-1/8			W - 7/8								
500-800	3/8		$(L + 2-1/4) \times D$	$(L + 2-1/4) \times (W + 2-1/4)$	1 x 3		W - 5	L - 2-3/4	L + 2-1/4	D - 5	D - 5	W - 2-3/4									
800-1,000			$(L + 2-1/2) \times D$	$(L + 2-1/2) \times (W + 2-1/2)$			1 x 4	W - 7	L - 4-3/4	L + 2-1/2	D - 7	D - 7	W - 4-3/4								
WHEN SPECIFIED	1/2	$(L + 2-1/2) \times D$	$(L + 2-1/2) \times (W + 2-1/2)$	1 x 4	W - 7	L - 4-1/2	L + 2-1/2	D - 7	D - 7	W - 4-1/2	1/8 x 1-3/8	1 3/8									

L - Container Length (inside dimension)  
 W - Container Width (inside dimension)  
 D - Container Depth (inside dimension)  
 Note: Chart measurements are in inches.

- Notes:
- Plywood will conform to exterior-grade plywood.
  - Lumber will conform to Class 2 structural. Structural lumber is 2 or more inches in thickness and width for use where working stresses are required.

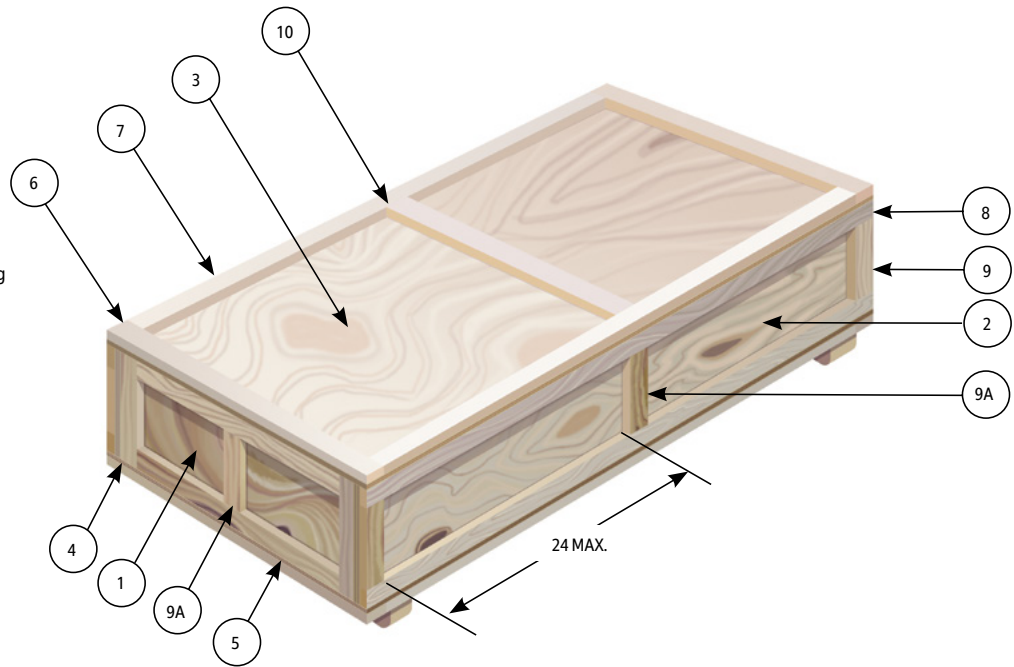

### Grades of Plywood

Grade	Appearance	Common Use
A	Free of knots; smooth, solid surface	Construction (cabinets)
B	Few knots; sanded, smooth surface	Construction, visible
C	Tight, open knot holes; face splits	Wood crates
D*	Lowest quality; not weather-resistant	Indoor-use construction

\* Not recommended for crate construction.



## Cushioning, Blocking and Bracing

Shock and vibration forces naturally occur during carriage of your goods throughout the shipping process; consequently, most products require some form of cushioning to protect them. Blocking and bracing are also important for larger commodities that cannot be boxed or crated. To effectively stabilize your shipment, remember to choose the type and size of lumber that's appropriate for the weight of your shipment.

### Foam Cushioning

When developing crates or packaging for your palletized shipments, foam is a natural option for cushioning. As part of the end design, cushioning should be engineered to provide the foam density required to protect the fragility level of the product. It should also be validated through testing that simulates the shipping environment. For FedEx shipments, we can help by testing your packaging and making recommendations.

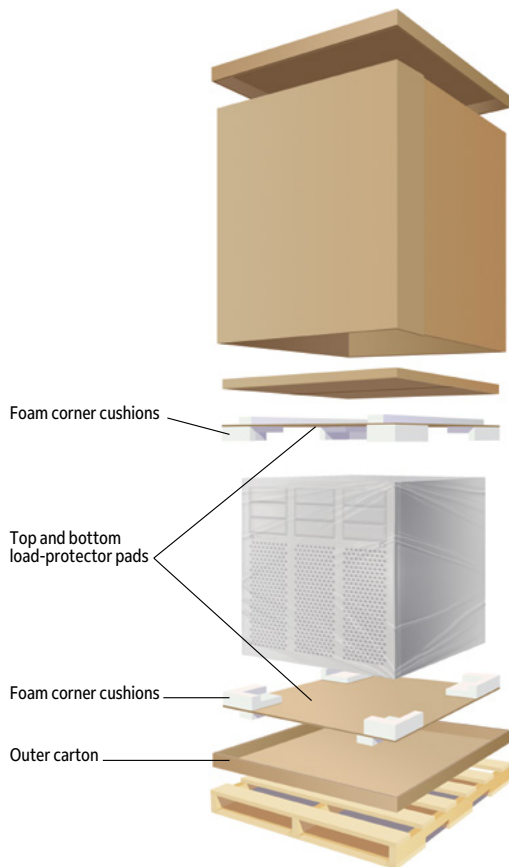

### Wood Blocking

The FedEx Packaging Lab suggests a blocking material such as wood be used to prevent any movement when

shipping single heavy goods. For goods that are over 1,500 lbs., we recommend that the pallet and blocking material be made from hardwood. The blocking should be placed tightly against the object with a goal of keeping it in a fixed position during all transportation and handling. As a general rule, blocking requires a minimum of two fasteners in each end to prevent pivoting and maintain adequate strength.

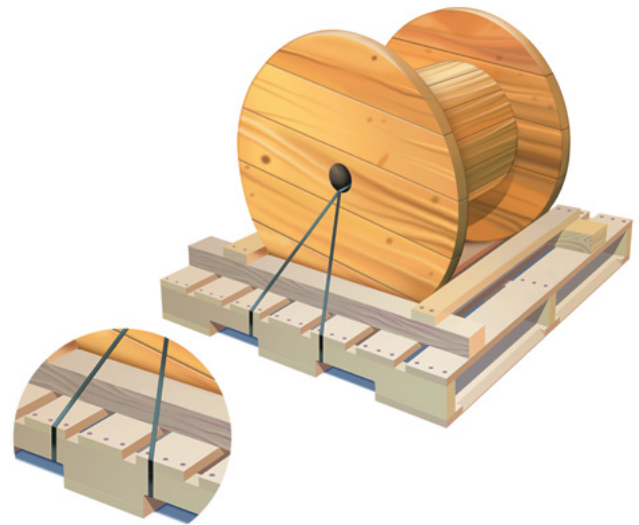

### Bracing

Items that can roll or shift during transportation due to their shape or size should be braced on a forkliftable pallet base for shipping. Your selection of lumber should be based on the product that you are bracing and its weight. As the shipping weight increases, the grade and thickness of the bracing lumber should increase. As an example, No. 3 (utility-grade) lumber is often used to construct pallets and for bracing materials. However, if the product you are shipping is very heavy, you should choose a better grade of wood, like a No. 1 or No. 2 grade (construction grade), for proper protection.

### Banding and Stretchwrapping

Typically, any damage during transit occurs because the shipment was improperly unitized, bundled or secured for transport. This is a particular issue with retail goods and boxed products. If there is cosmetic carton damage, the customer is likely to assume the contents are also damaged. As discussed earlier, pallet strength and stacking play an important role in freight shipment integrity. So do load protection, stretchwrapping and banding, which we will cover here.

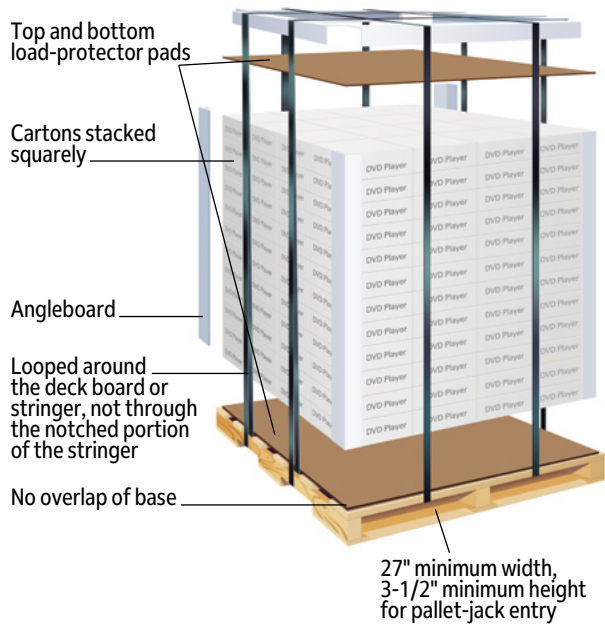

### Load Protectors and Edge Boards

Top and bottom load-protector pads (corrugated pad/tray) help reduce damage to top and bottom layers of your shipment. They also help distribute the weight of top-loaded freight. Bottom load protectors provide a level surface, offer protection from pallet nail heads, and help keep boxes from slipping into the gap between the boards on the pallet. A corrugated pad between stacked layers (tier sheet) will also help stabilize packages and distribute weight. Angleboards along the unit edges should run the full length or depth of the stack to help unitize the load, increase vertical stacking strength and reduce damage to box edges that make up the load corners.

### Bands

Banding is typically used to secure the bundled load to the pallet. You should band corrugated stacks on each side as shown. As a general rule, keep the banding close to the load to avoid exposure, damage or breakage. Loads significantly smaller than the pallet should be centered and banded to the closest pallet deck boards vs. the pallet exterior. The more perpendicular the banding is, the greater its holding force. All palletized loads being shipped via FedEx Express Freight require banding with heavy-duty steel, rayon, polypropylene, nylon or polyester strapping.

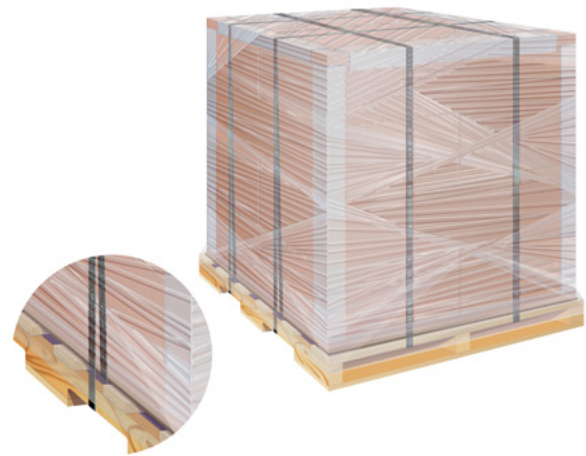

### Stretchwrap

Stretchwrap film is critical for bundling loads and also for securing and protecting large individual pieces of freight. Wrap freight tightly to prevent load shifting. Use 70-gauge stretchwrap that sticks to itself so it can be wipe-sealed as it is applied to the stack. When machine wrapping, spiral-wrap the cartons with a minimum 50 percent overlap. Proper application includes a secure wrapping along the pallet perimeter and a 3" overlap at the top of the stack.

To manually apply stretchwrap, tuck the lead wrap between the pallet and the bottom box. Spiral around the boxes in an upward direction, overlapping the film by 50 percent. When you reach the top, stretch the film diagonally over the top corners with a 3" overlap to anchor the stack vertically before spiraling back to the bottom to finish the load with a secure wrapping along the pallet perimeter.



Based on the weight and stability of your shipment, the FedEx Packaging Lab recommends the following wrap standards. Achieving the minimum containment force is critical for properly securing freight to the pallet. For

unstable and mixed loads, “roping” the stretchwrap can help contain freight and prevent the stretchwrap from fraying and tearing.

**Stretchwrap Guidelines**

Weight of Pallet Load	Containment Force	Bottom Wrap* (Includes Pallet)	Top Wrap*
0-500 lbs.	2-5 lbs.	3	2
501-750 lbs.	5-7 lbs.	4	3
751-1,000 lbs.	7-12 lbs.	5	4
1,001-1,500 lbs.	12-20 lbs.	6	6
Over 1,501 lbs.	20+ lbs.	8	8

\* Wrap indicates layers of stretchwrap film.  
 \* Any shipment over 1,000 lbs. should also have bands along with stretchwrap.

**Securing Unique Freight**

Some uniquely shaped items such as tires, bags, drums, spools, transit cases, engines, pipes, and medical or electronic equipment require special packaging. FedEx highly recommends that all packaging systems be tested to validate the performance of your design. Improper packaging of these freight shipments can disrupt service, causing product damage or shipping delays. We'll explore ways to palletize/crate and secure these types of shipments here.

For additional details, please review commodity industry packing standards.

**Tires**

Band and stretchwrap a tire or multiple tires to a pallet for freight shipping. The FedEx Packaging Lab also recommends an anti skid surface for tall stacks to reduce product movement. To complete your shipment, use a tie-on tag, tire/crate label or designated tire label. Contact your account executive for assistance to select the best option for your needs.

**Aircraft Tire**

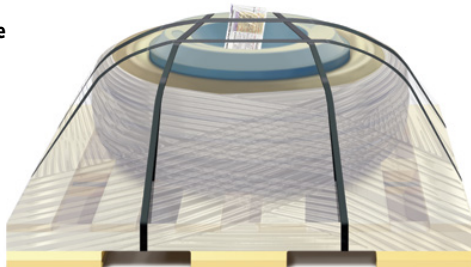

**Truck and Auto Tires**

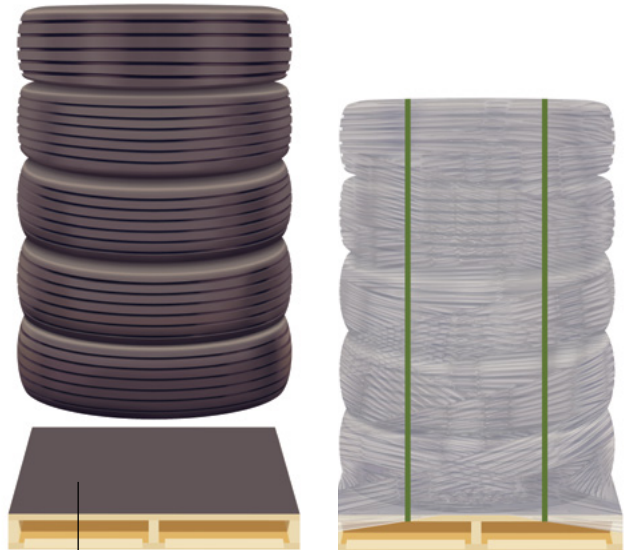

Antiskid surface

**Bags**

Place a corrugated tray down to help prevent bag puncture and use the interlock stacking method and tier sheets to help guard against products shifting during transit. Use a second tray to cover the unitized load. Pallet trays need to be 1.5x the depth of the first layer of bags. All bags must stay well within the pallet perimeter using stretch wrap and banding. Cushion the unitized perimeter with corrugated boards as necessary.

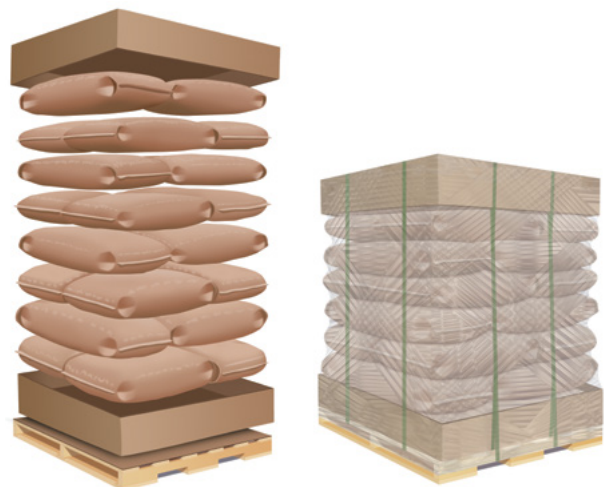



## Drums and Pails

Often containing liquid, drums and pails have a tendency to shift in transit, so it is necessary to adequately secure the freight to a pallet. The same basic banding, edge-protection and stretchwrapping recommendations apply to these shipments. A solid pallet deck or anti-skid surface is also recommended. Do not exceed two drums or three pails in height on a pallet. These stacked units should be nestable. Multiple units in a tier should also be horizontally banded around the perimeter. Only FedEx Freight allows non-palletized drum shipments.



FedEx Freight® shipments only

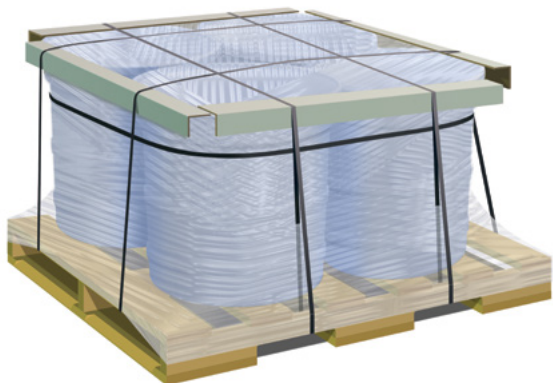

## Spools

Spools and reels tend to roll and shift during transit and are difficult to lift, so they should be secured to a forkliftable pallet. Use blocking and bracing to securely anchor spools and reels.

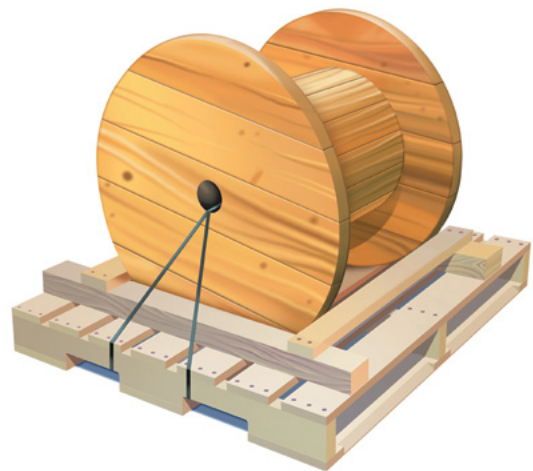

## Transit Cases

If you are shipping transit cases with caster wheels, they must be palletized. Remove the wheels or use traditional blocking methods to prevent movement on the skid. If the wheels are not removed, the pallet deck must be solid to prevent wheels from falling through the slats and being damaged by the forklift. It may be easier to raise the wheeled case or item up on blocks to suspend the wheels off the deck and prevent shifting.



TSA regulations require that any shipment weighing over 150 lbs. or large enough to house a human must be locked or be secured with two bands in each direction (four bands total).

## Engines and Other Exposed Items

Drain the item of all fluids. Securely mount the item to the pallet deck. Internally block and brace the item and use sturdy expendable packaging (corrugated or wood) around the product. Add stretchwrap and banding for additional protection and containment.

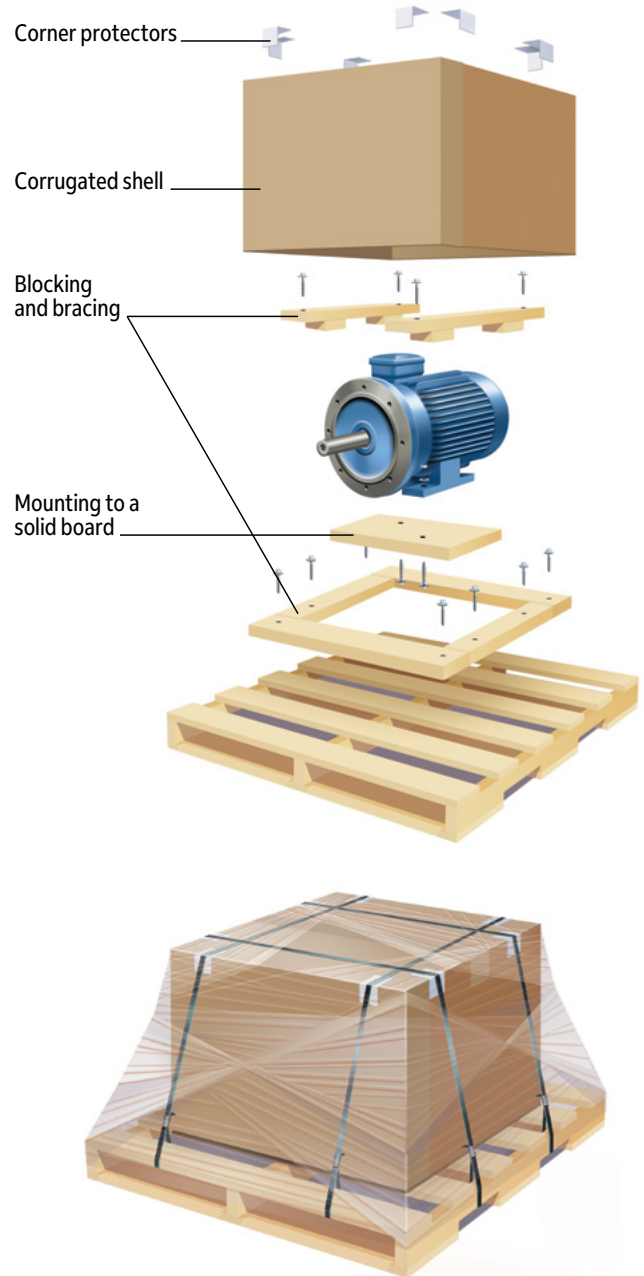

## Pipes and Other Long Freight

When it comes to shipping pipes and other long objects that could puncture a package or damage aircraft and trucks, it's important to bundle, secure and crate them for freight shipment. These three design concepts represent acceptable options for freight shipping because they can be double-stacked, they enable proper handling by mechanical equipment, and labels and paperwork will adhere to the exterior surface.

Chamfering the ends of elongated stringers allows them to be dragged in and out of containers without damaging the pallet. This is especially important when moving extra-long freight that can't be picked up from the end.



Reddi-Crate® design

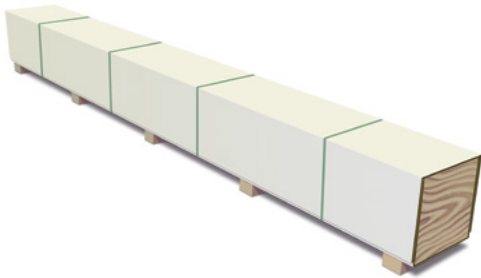

Reddi-Crate® is a registered trademark of Signode Industrial Group LLC.

OptiLedge® design

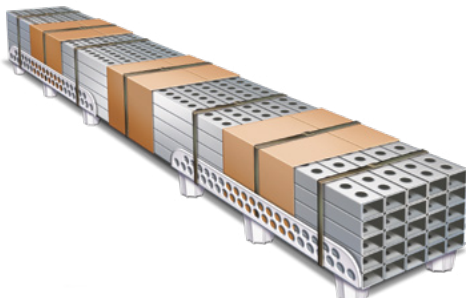

OptiLedge is a registered trademark of OptiLedge LLC.

## NOT RECOMMENDED: Banding and Blocking Pipes and Other Long Freight to a Pallet

Banding long freight, or non-profile freight such as pipes, unprotected to a pallet is not recommended, because it does not provide outer protection for double stacking, there is no blocking on the ends to prohibit side-to-side shifting, and shipping labels might not adhere to an uneven surface.

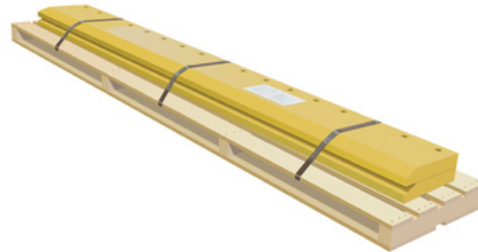

## Large, Flat Items and Packages

Large, flat items (such as mirrors, artwork, doors, windows, countertops, etc.) should be packaged in an appropriate sturdy shipping container. To maintain a vertical shipping orientation, the package must also be braced on an elongated pallet. Integrated A-frames, crate bracing and bookend bracing designs (as represented below) have proven successful.

The pallet and bracing framework should be engineered to support the load with no product or package overhang. The pallet must also be wide enough to prevent load tipping of tall units. As general rule for unit stability, the pallet base width should be greater than half the unit's center of gravity or unit height. The center of gravity should be identified for all unbalanced freight, crated products and freight known to be off center or heavier at one edge or end.





## Sensitive Electronic and Medical Equipment

Start with a properly designed pallet. It's important to ensure that the pallet is compatible with forklifts, pallet jacks, and other warehouse handling devices. Crate or effectively enclose the product to protect from external shipping forces, including potential stacking, and also cushion or restrain the package interior to prevent product shifting. As necessary the product can be bolted to the pallet deck. Use banding and stretchwrap to securely contain the load on the pallet. The general example below is for a copier. Similar sensitive, fragile, electronic or expensive items or equipment may need appropriately engineered package protection.

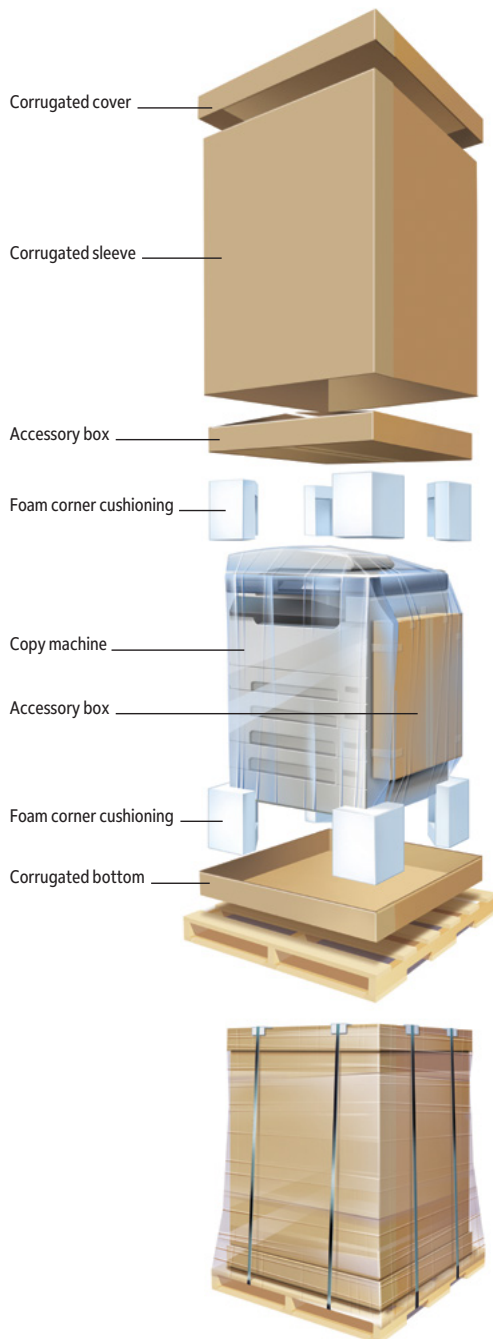

## Marking and Labeling

Handling labels and marking should be clearly visible and positioned on the sides you prefer for forklift entry. Remove or mark out any old labels, tags and markings.

### Marks and Labels

Use descriptive marks or labels to help us identify your shipping requests. Common labels per ASTM include “This End Up,” “Do Not Stack,” “Fragile,” “Handle With Care,” and “Center of Gravity.” While we cannot ensure compliance with markings such as up arrows or “This End Up,” properly placing the shipping label increases your chance for the preferred orientation. “Do Not Stack” requests cannot always be accommodated, so all freight shipments should be designed to support potential stacking. A surcharge applies to any piece, skid or pallet of a FedEx Express freight shipment that is nonstackable. For details on the surcharge, please see the Rates and Surcharges section of the FedEx Service Guide at [fedex.com](https://www.fedex.com).

Although warning stickers can be placed on the outside of the packaging, shipping indicators designed to track the shipping environment, such as a shock-watch or tilt-watch meters, should be mounted (with void space) inside packaging to simulate the actual product shipping environment and reduce the effects of exterior forces to avoid false readings. They should be applied as recommended by the manufacturer in the proper orientation. You may use these indicators for reference, but neither FedEx Express Freight nor FedEx Freight honors claims exclusively as a result of their response. See the applicable terms and conditions for limitations on liability and liabilities not assumed.



## Tire Labels, Tire/Crate Labels and Tie-On Tags

FedEx Express offers direct thermal tire labels designed to be printed and applied directly to tire treads. This is a one step process opposed to the tire/crate label. The tire/crate label serves as a foundation for your shipping label. It features a strong adhesive to ensure an intact seal during transit, but it comes off in one piece when removed at its destination. For FedEx Express Freight shipments, you can request tire/crate labels, tie-on tags and cable ties at [fedex.com](https://fedex.com), or call 1.800.GoFedEx 1.800.463.3339. You may also contact your account executive for other packaging supplies.



Tire/Crate Labels



Tie-On Tags

## Shipping Dangerous Goods

Dangerous goods are everywhere. Perfume, oil paint art kits, and laptop computers are all considered dangerous goods during transport. Under some circumstances these everyday items can harm people, property, and the environment. Protect your shipment and yourself by identifying dangerous goods and properly packaging and preparing every shipment.

## Package Your Shipments Correctly

Some dangerous goods have specific packaging, labeling, and marking requirements. All require a completed Shipper's Declaration for Dangerous Goods form. For information on the proper shipment preparation for IATA and ICAO shipments of non-radioactive items, go to [https://www.fedex.com/content/dam/fedex/us-united-states/services/DG\\_Job\\_Aid.pdf](https://www.fedex.com/content/dam/fedex/us-united-states/services/DG_Job_Aid.pdf).

## Protect Yourself

Shippers who do not prepare their packages according to IATA and ICAO regulations can be fined by regulatory authorities and may even face criminal prosecution and imprisonment. The federal government requires people to be trained and certified to handle and prepare dangerous goods shipments. FedEx conducts training seminars throughout the year. To view schedules and register for a seminar, go to <https://fedex.registration.meetingevolution.net/>.

## Common Dangerous Goods

- Aerosols
- Ammunition
- Batteries (lithium and wet)
- Camping stoves
- Chemicals
- Drain cleaners
- Fireworks
- Lighters
- Matches
- Oil-based paint
- Parts (containing gasoline, jet fuel or kerosene)
- Perfume
- Propane
- Radioactive materials
- Solvents

## FedEx Express Freight and FedEx Freight Size and Weight Limits

When choosing your freight service, follow these guidelines to determine if your shipments meet the criteria for acceptable size and weight limits.

CRITERIA	U.S. EXPRESS FREIGHT	INTERNATIONAL EXPRESS FREIGHT	INTERNATIONAL AIR CARGO	FEDEX FREIGHT
	<ul style="list-style-type: none"> <li>FedEx First Overnight® Freight</li> <li>FedEx 1Day® Freight</li> <li>FedEx 2Day® Freight</li> <li>FedEx 3Day® Freight</li> </ul>	<ul style="list-style-type: none"> <li>FedEx International Priority® Freight</li> <li>FedEx International Economy® Freight</li> </ul>	<ul style="list-style-type: none"> <li>FedEx International Premium®</li> <li>FedEx International Express Freight™</li> <li>FedEx International Airport-to-Airport<sup>SM</sup></li> </ul>	<ul style="list-style-type: none"> <li>FedEx Freight® Priority</li> <li>FedEx Freight® Economy</li> <li>FedEx Freight® Direct</li> </ul>
Minimum weight per piece (skid) or shipment	151 lbs. (68 kg) <sup>1,3</sup>	151 lbs. (68 kg) <sup>1,4</sup>	No minimum restrictions <sup>5</sup>	No minimum restrictions <sup>5</sup>
Maximum weight per piece (skid)	2,200 lbs. (997 kg) <sup>2</sup>	2,200 lbs. (997 kg) <sup>2</sup>	2,200 lbs. (997 kg) <sup>2</sup>	3,150 lbs. (1,429 kg) <sup>2,5</sup> 1,500 lbs. (680 kg) FedEx Freight Direct <sup>7,8</sup>
Maximum weight per shipment	Unlimited	Unlimited	Unlimited	20,000 lbs. (9,072 kg) <sup>2</sup>
Maximum length per piece (skid)	119" (302 cm) <sup>2</sup>	119" (302 cm) <sup>2</sup>	119" (302 cm) <sup>2</sup>	20' (6 m) <sup>2</sup> 96" (243 cm) FedEx Freight Direct <sup>9</sup>
Maximum height per piece (skid)	70" (178 cm) <sup>2</sup>	70" (178 cm) <sup>2</sup>	70" (178 cm) <sup>2</sup>	100" door access (254 cm) <sup>2,9</sup>
Maximum width per piece (skid)	80" (203 cm) <sup>2</sup>	80" (203 cm) <sup>2</sup>	80" (203 cm) <sup>2</sup>	93" (236 cm) <sup>2,9</sup>

<sup>1</sup> Minimum billable weight is 151 lbs. regardless of actual weight.

<sup>2</sup> Individual pieces (skids) or shipments exceeding the maximum size and weight exceptions require prior approval from FedEx Express Freight Customer Service at 1.800.332.0807 or FedEx Freight Customer Service at 1.866.393.4585.

<sup>3</sup> Pieces weighing less than 151 lbs. that exceed 165" in length and girth combined ("extra-large" packages) may be accepted as FedEx Express® Freight U.S. shipments. These pieces do not have to be palletized (skidded), stackable or forkliftable. See the current FedEx Service Guide for more information.

<sup>4</sup> Unskidded pieces less than 151 lbs. (68 kg) can be accepted as FedEx International Priority Freight or FedEx International Economy Freight only if the length plus girth exceeds 130" (called Extra Large Package) and are subject to a billable weight of 151 lbs.

<sup>5</sup> Based on weight being evenly distributed on a standard skid.

<sup>6</sup> Another FedEx® service may be better suited for shipments less than 151 lbs. (68 kg).

<sup>7</sup> For any FedEx Freight Direct shipment that exceeds 150 lbs., the service will be upgraded with applicable charges to apply.

<sup>8</sup> For any FedEx Freight Direct Shipment that exceeds 300 lbs., the service will require written preapproval from Carrier before acceptance and may require an upgrade in service and/or an additional charge.

<sup>9</sup> For any FedEx Freight Direct shipment that exceeds 96" and/or 250" in length and girth combined, the service will require written preapproval from Carrier before acceptance and may require an upgrade in service and/or an additional charge.

## Contacts and Resources

- FedEx Freight packaging essentials and tips, [fedex.com/packagingfreight](https://www.fedex.com/packagingfreight).
- FedEx Packaging Lab, [packagingservices@fedex.com](mailto:packagingservices@fedex.com) or 1.800.633.7019.
- FedEx Service Guide at [fedex.com/us/services](https://www.fedex.com/us/services) for terms and conditions governing FedEx Express Freight and FedEx Freight shipments.
- FedEx Express Freight Customer Service, 1.800.332.0807.
- FedEx Freight Customer Service, 1.866.393.4585.
- [www.usda.gov](https://www.usda.gov); enter search words "wood packaging materials."

**NOTICE:** This packaging brochure is provided free to FedEx customers to help reduce loss or damage due to improper packaging. It is NOT intended to be a comprehensive guide for packaging items we accept for transit. We make no warranties, expressed or implied, regarding this information. Proper packaging is the sole responsibility of the shipper. For more information and additional guidelines, go to the packaging tips page on [fedex.com/packagingfreight](https://www.fedex.com/packagingfreight), email [packagingservices@fedex.com](mailto:packagingservices@fedex.com) or contact the FedEx Packaging Lab at 1.800.633.7019. Refer to the current FedEx Service Guide for terms, conditions and limitations applicable to FedEx® delivery services.

© 2020 FedEx. All rights reserved.

Rev. 5/20